

Wadkin

Electric Straight Line Edger Type P.U.

This machine has been specially developed to deal with all kinds of ripping at a high rate of output. It is capable of edging the stock accurately so that no further machining operations are required for glued joints.

There are two models available :—

P.U.1 will admit timber up to 24" x 4" section, between the saw and the inside of the arms.

P.U.2 will admit timber up to 24" x 4" section, and also up to 30" x 1½" section, between the saw and the arms.

PRINCIPAL DIMENSIONS AND CAPACITIES

Maximum diameter of Saw	17"
Minimum diameter of Saw	10"
Shortest Length of Cut	12"
Size of Table	6' 9" x 4' 11½"
Width of Table at right of Saw	2' 9"
Width of Table at left of Saw	2' 21"
Height of Table	2' 11"
Standard Rates of Feed in feet per minute	50-75-100-150
Horse-power of Feed Motor	3
Speed of Saw Spindle in r.p.m. on 50 cycle supply	2,800
Standard Horse-power of Saw Motor	15
(Larger Motors up to 25 Horse-power for heavy work.)								
Net weight	46 cwts.

DETAILS INCLUDED WITH MACHINE

Saw jointing device. Fence for table. Lubricating Pump and tin of lubricant. One set of spanners. Dust collecting hopper and pipe connection. Oil Gun.

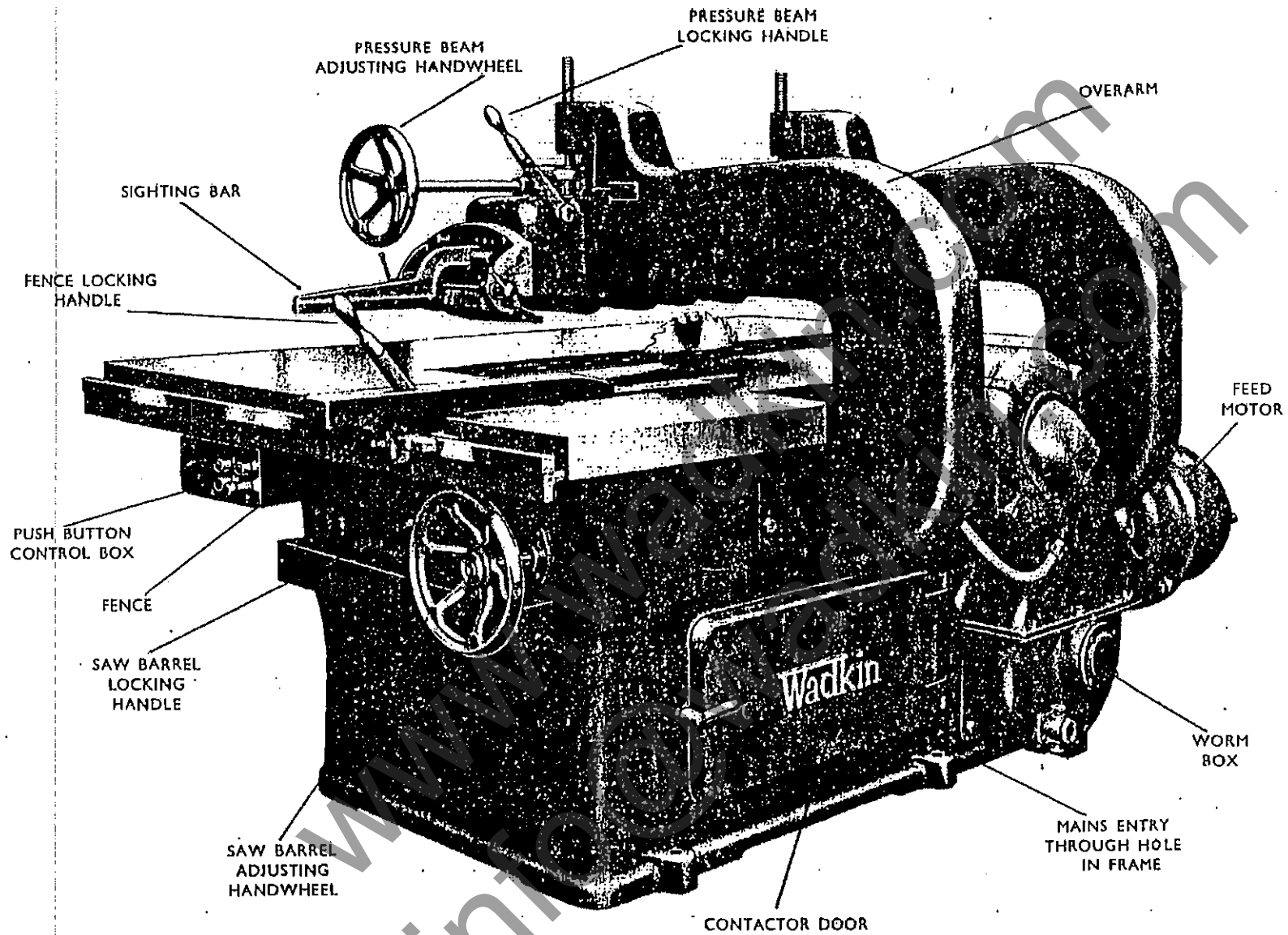
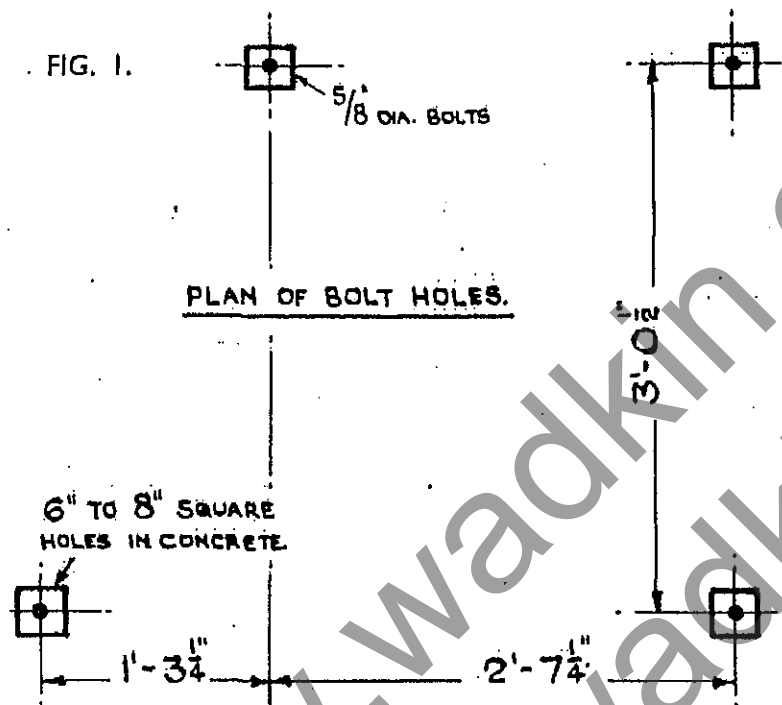

FIG. 1. Page 2

INSTALLATION



The machine is despatched from the Works with all bright surfaces greased to prevent rusting. This must be removed by applying a cloth damped in paraffin or turpentine.

FOUNDATIONS

1/2" diameter foundation bolts should be used to bolt the machine down to the floor. If the mill floor consists of 6" solid concrete, no special foundation is necessary. Rag type holding down bolts may be used, and as shown on the foundation plan, 6" to 8" square holes should be cut in the concrete and the machine, after careful levelling, grouted in with liquid cement.

WIRING

It is necessary to fit a triple pole isolating switch adjacent to the machine to enable the electrical gear on the machine to be readily isolated for inspection purposes.

If desired it can be obtained from Wadkin Ltd. to special order. The mains entry is shown in the general view of the machine, Fig. 1, and the three mains wires should be connected to the terminals L1, L2, L3 as shown on the wiring diagram, Page 21, and connect the machine to earth.

For detailed cabling particulars see Page 18.

DUST EXTRACTION UNIT

The machine has a 7" x 3 1/2" outside rectangular exhaust outlet for connecting to dust extraction piping, the exhaust hood being built in the machine.

SPECIAL NOTE.—Dust extraction equipment must be used with this machine. We cannot take any responsibility for the machine, if it is used without extraction equipment.

THE SAW

The saw is spigotted on the back saw collar and driven by a driving peg. Use the special ring spanner provided to lock up. Access to the spindle end is obtained by opening the door, Fig. 2.

SAW ADJUSTMENTS

The handwheel on the feeding in side of the main frame is used for raising and lowering the saw "B," Fig. 3, and the saw barrel should always be locked after adjusting, with the handle, Fig. 3. The best results are obtained with the saw teeth just projecting through the timber, always use the smallest diameter saw possible for cutting all timber including plywood. When cutting timber wider than 24" to right of saw, the saw must be set in its lowest position to bring the flat on the saw motor flange below the table level as shown in Fig. 3.

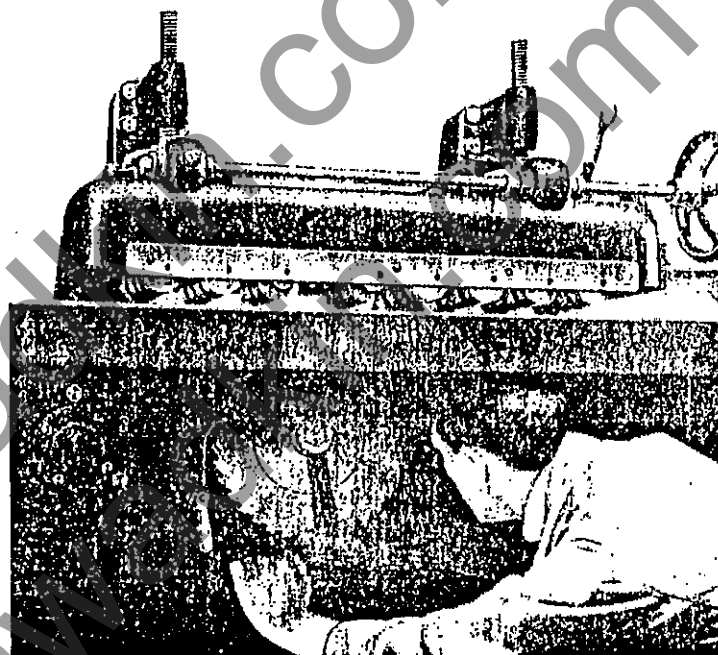

FIG. 2.

PRESSURE BEAM ADJUSTMENT

Adjust the pressure beam to suit thickness of timber by rotating handwheel, Fig. 1. Use the minimum pressure which gives satisfactory results. By setting the feed beam scale to the thickness of material being cut, an $\frac{1}{8}$ " pressure is automatically allowed in the setting of the beam, and this pressure should be sufficient.

Always lock after resetting by moving the handle A, Fig. 4, this lock can be adjusted by turning the nuts on the clamp arm screws, B Fig. 4, these nuts must be adjusted by an equal amount.

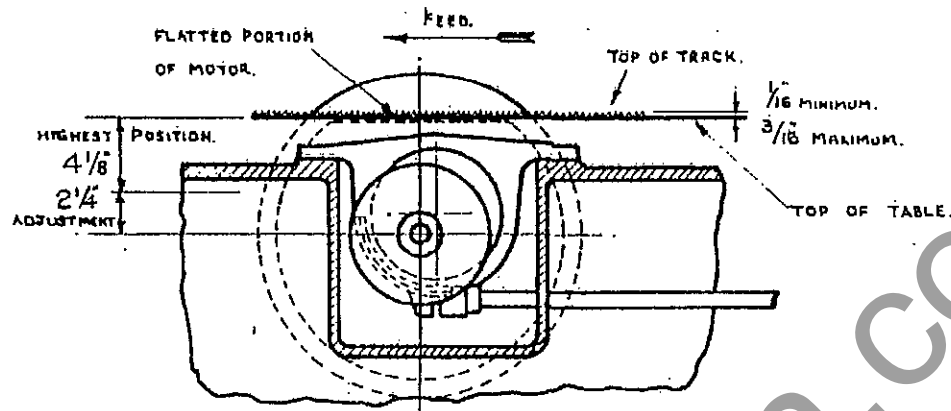
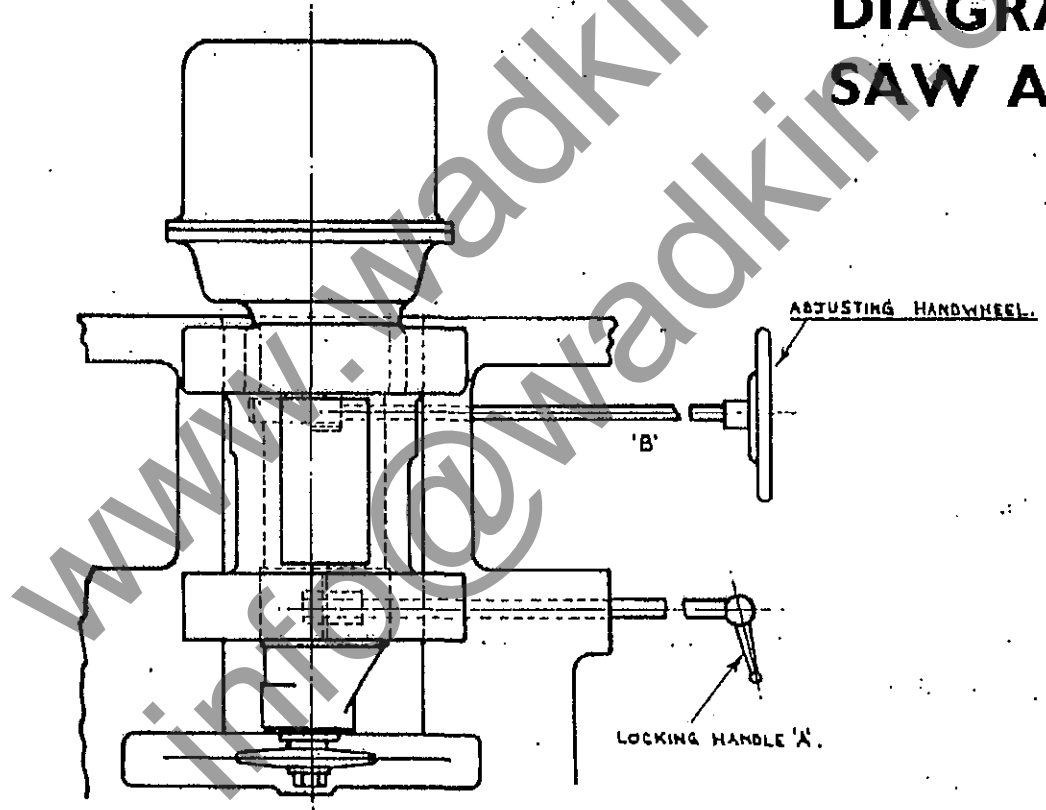

DIAGRAM OF SAW ADJUSTMENT

FIG. 3.



PRESSURE BEAM ADJUSTMENT (View from Rear of Machine)

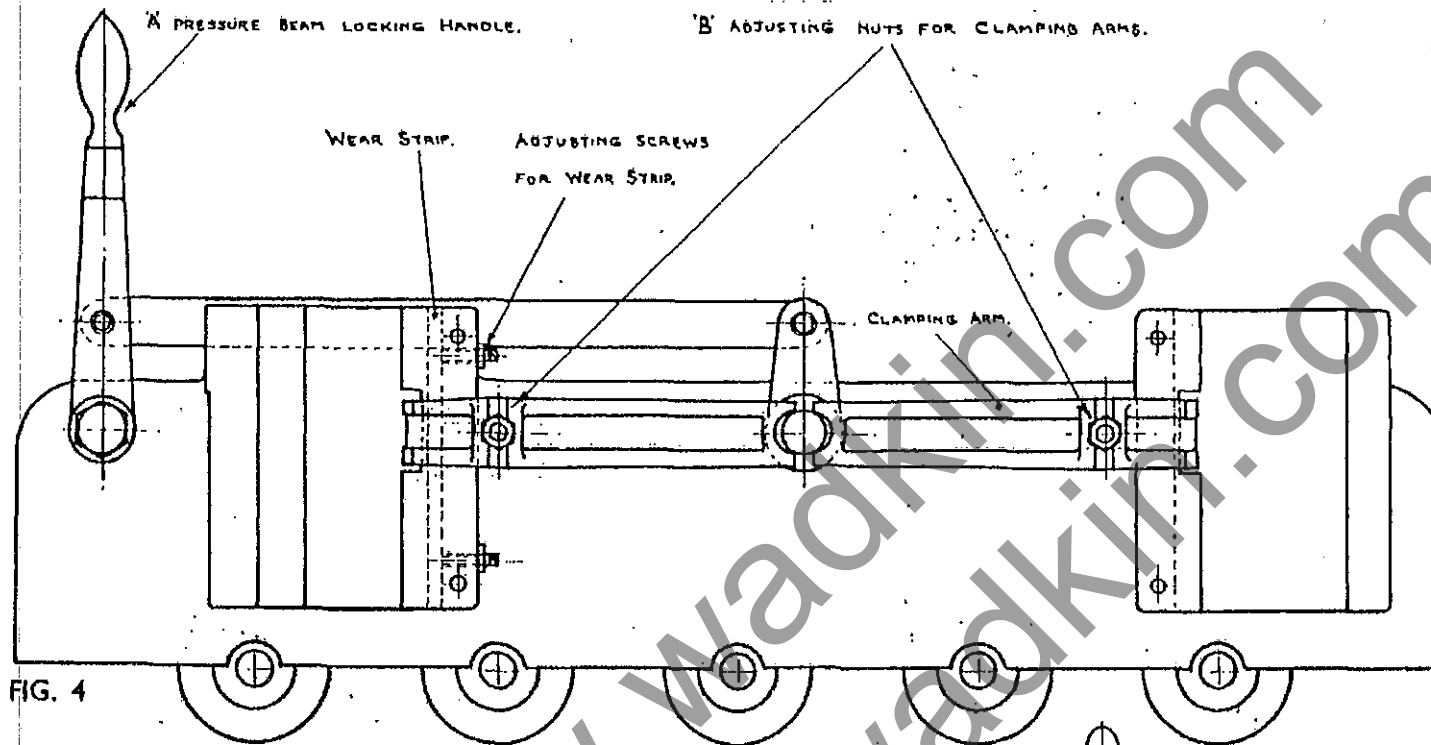

FIG. 4

THE FENCE

The fence may be set and worked either side of the saw.

The locking handle as shown at "A," Fig. 5, can be adjusted by the square head screw "B" on the rocking lever.

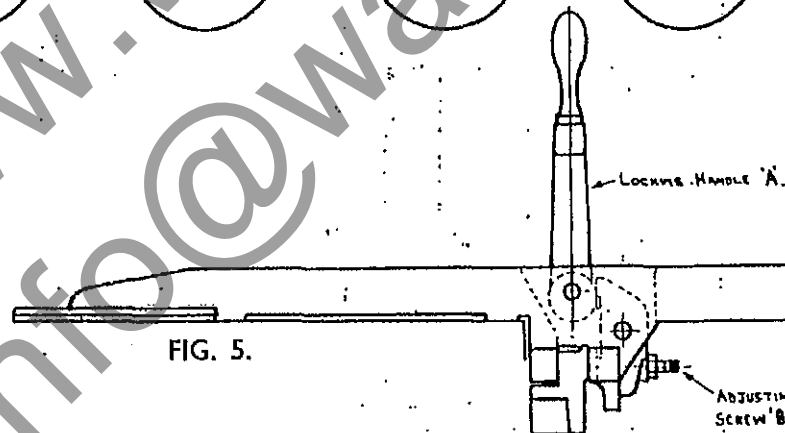

FIG. 5.

SIGHTING BAR AND FINGER GUARD ADJUSTMENT

The sighting bar can be adjusted by slackening the nut on top of the pressure beam and on the feeding in end of the pressure beam, moved either to right or left and the nuts locked up again.

The fingers on the finger guard are clamped together by the handle on the right hand side, Fig. 1.

BED CHAIN SLIDE ADJUSTMENT

The bed chain slide is set square with the saw spindle and bolted on to four sleeves "A," Fig. 6, in the main frame. These sleeves are vertically adjustable to vary the height of the bed chain above the table level. This adjustment,

as shown in Fig. 3, varies from $\frac{1}{8}$ " minimum to $\frac{1}{4}$ " maximum. Adjust all four points an equal amount by unlocking the nut "B," Fig. 6, and the clamping bolt "C"; rotate the sleeve "A" by inserting a tommy bar in the holes provided; finally locking the nut "B," and clamping bolt "C."

The "lead on" quadrants are set to give straight line cutting, and can be adjusted to give either round or hollow cuts as desired. Setting both quadrants to give right hand lead (Fig. 7) gives a round cut and setting to left hand lead gives a hollow cut, both when edging with the timber to the left of saw.

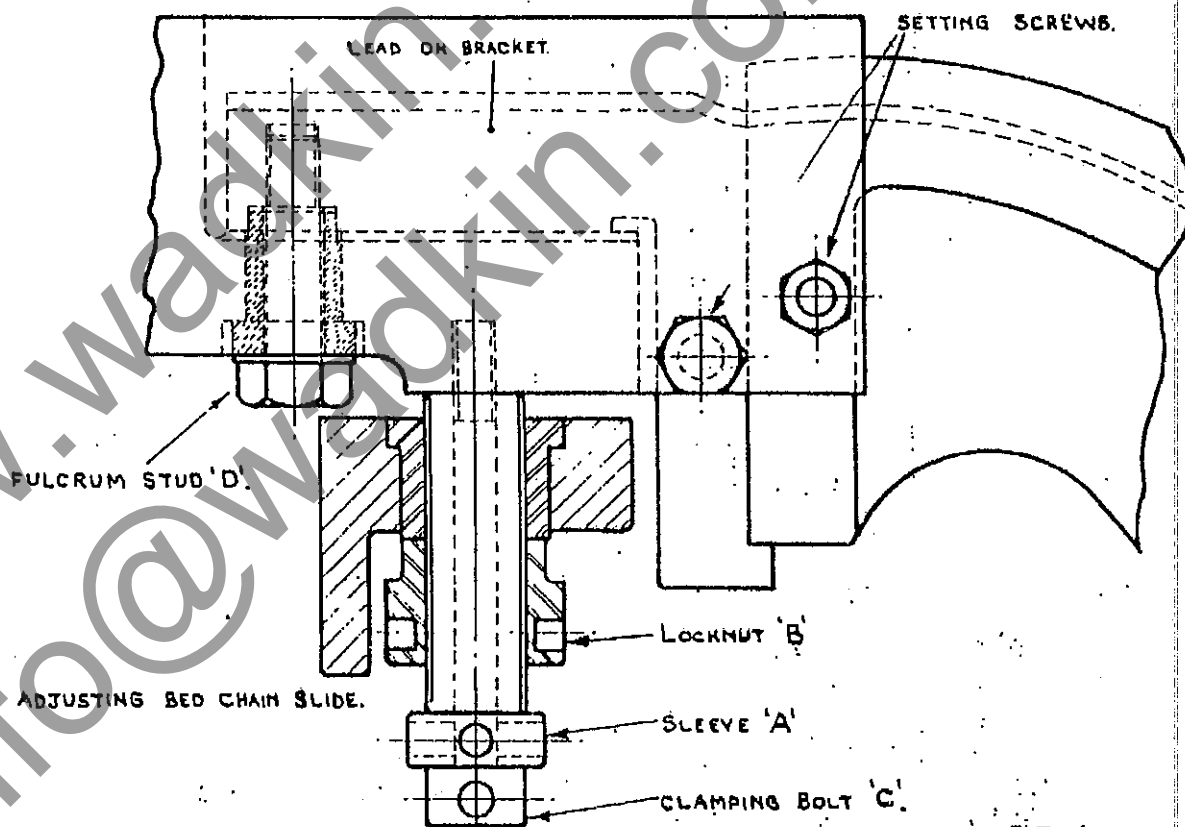
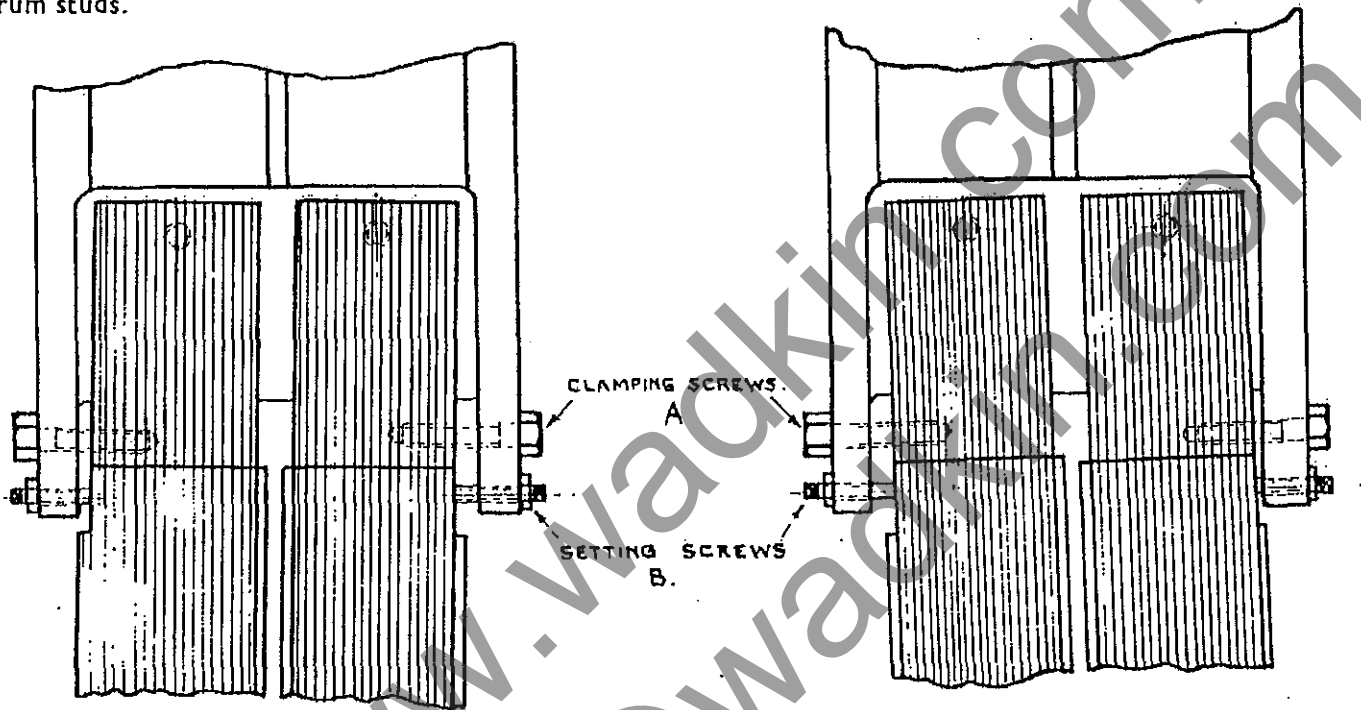

FIG. 6

BED CHAIN SLIDE ADJUSTMENT (continued)

The curvature is reversed if the timber is worked to the right of the saw. To adjust the quadrant, slacken fulcrum stud "D," Fig. 6, release the clamping screws "A," Fig. 7, and the locknuts on the square head screws "B," turn the square head screws until the desired lead is obtained and lock, then clamp with the screws "A" and lock the fulcrum studs.



SHOWING EXAGGERATED RIGHT HAND LEAD

FIG. 7.

SHOWING EXAGGERATED LEFT HAND LEAD.

SELECTING FEED SPEED

The correct feed speed is selected by turning the selector switch to the desired speed and then depressing the "start feed" button. The feed will not operate until the saw motor is running. The master stop button is fitted with a "lock out" arrangement to ensure the start buttons are inoperative during setting up, etc. When cutting short lengths of timber, select the feed speed that allows the lengths to butt up end to end to allow continuous cutting when feeding through.

LUBRICATION

It is essential that only Wadkin recommended ball bearing Grease is used. The recommended lubricants are shown on the lubrication charts, Figs. 9 and 10. If however, it is desired to use lubricants other than Wadkin, the equivalents are listed below:—

Ball Bearing Grease	...	Wadkin Grade L6 or Shell "NERITA" GREASE 3 or Mobil Oil Co. MOBILUX GREASE No. 2 or CALTEX "REGAL STARFAK No. 2 GREASE".
Good Quality Machine Oil	...	Wadkin Grade L4 or Shell "VITREA" OIL 33 or Mobil Oil Co. "VACTRA" OIL (Heavy Medium) or CALTEX "ALEPH OIL".
Heavy Gear Oil	...	Wadkin Grade L2 or Shell "VITREA" OIL 69 or Mobil Oil Co. MOBIL OIL DTE, BB. or CALTEX "MEROPA No 2 OIL".
Special Oil for Pressure Rollers	...	Wadkin Grade L1 or Shell "VITREA" OIL 27 or Mobil Oil Co. MOBIL DTE OIL (Light Special) or CALTEX "REGAL OIL B (R & O)".

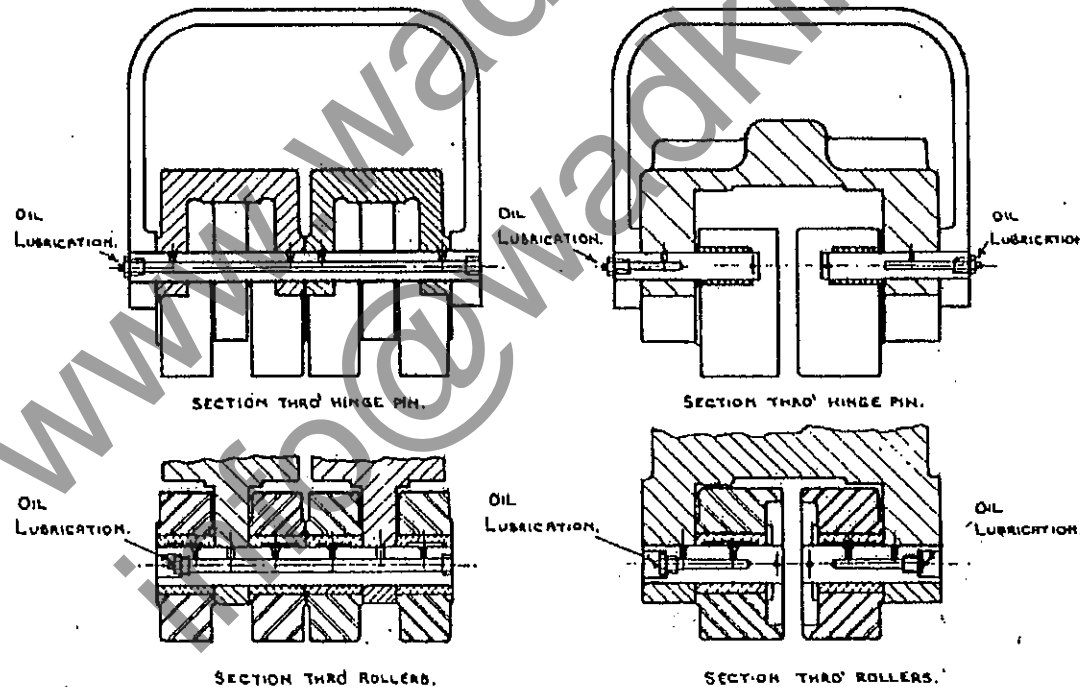

PRESSURE ROLLERS

The pressure rollers and hinge pins should be given one charge or depression of the oil gun daily, at the points illustrated on Fig. 8.

A special box spanner is supplied for removing the oil nipples should they require cleaning.

LUBRICATION CHART

- A Ball Bearings, give four to six charges of grease gun every three months, using Wadkin Grease, Grade L6.
- B Give one charge of grease gun daily, using Wadkin Grease, Grade L6.
- C Give one charge of grease gun monthly, using Wadkin Grease, Grade L6.
- D Oil daily, three to four drops, using Wadkin Oil, Grade L4.
- E Check daily and fill to oil level, using Wadkin Oil, Grade L4.
- F Check monthly and fill to oil level, using Wadkin Oil, Grade L2.
- G Give one charge or depression of the oil gun daily, using Wadkin Oil, Grade L1.

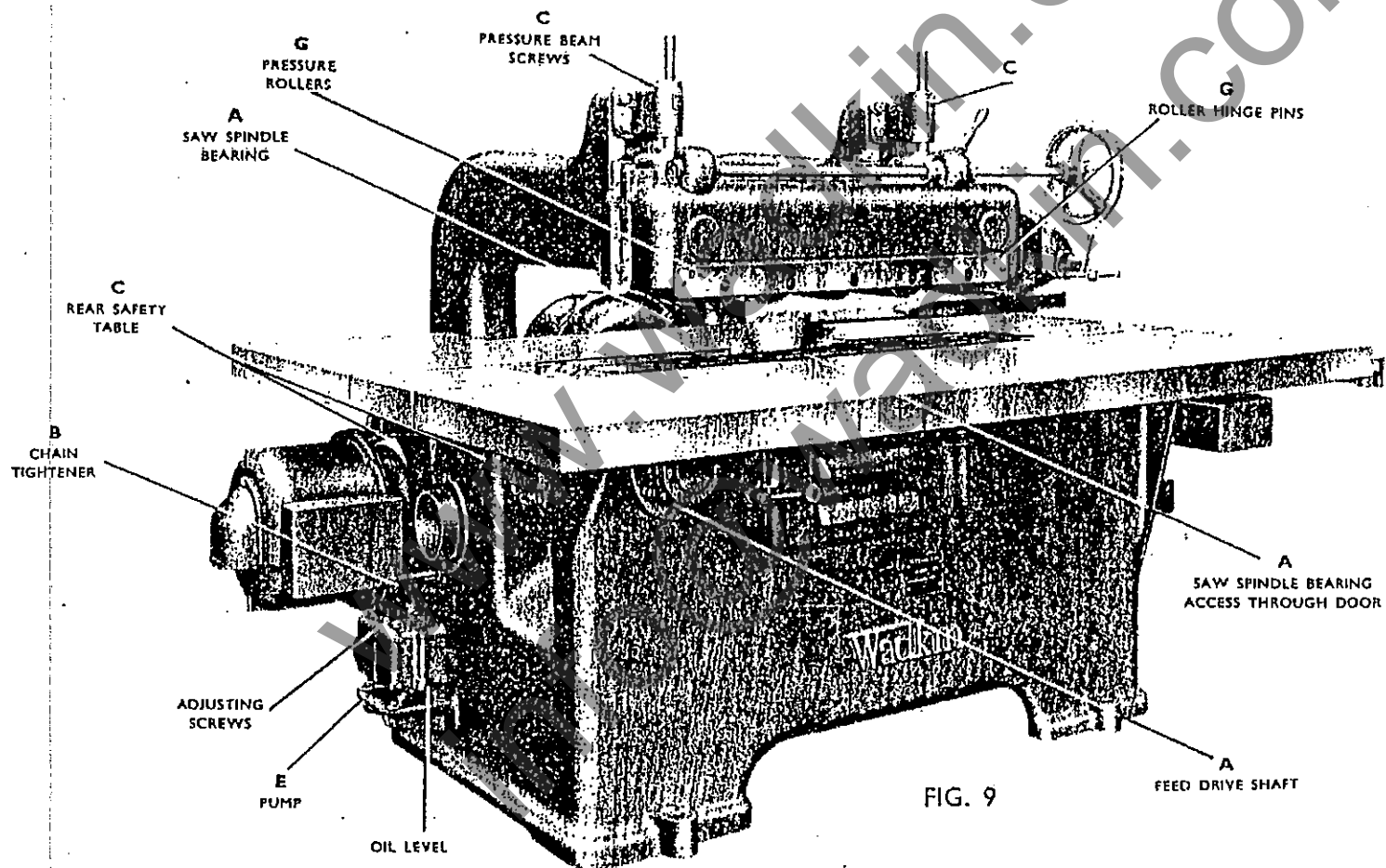

FIG. 9

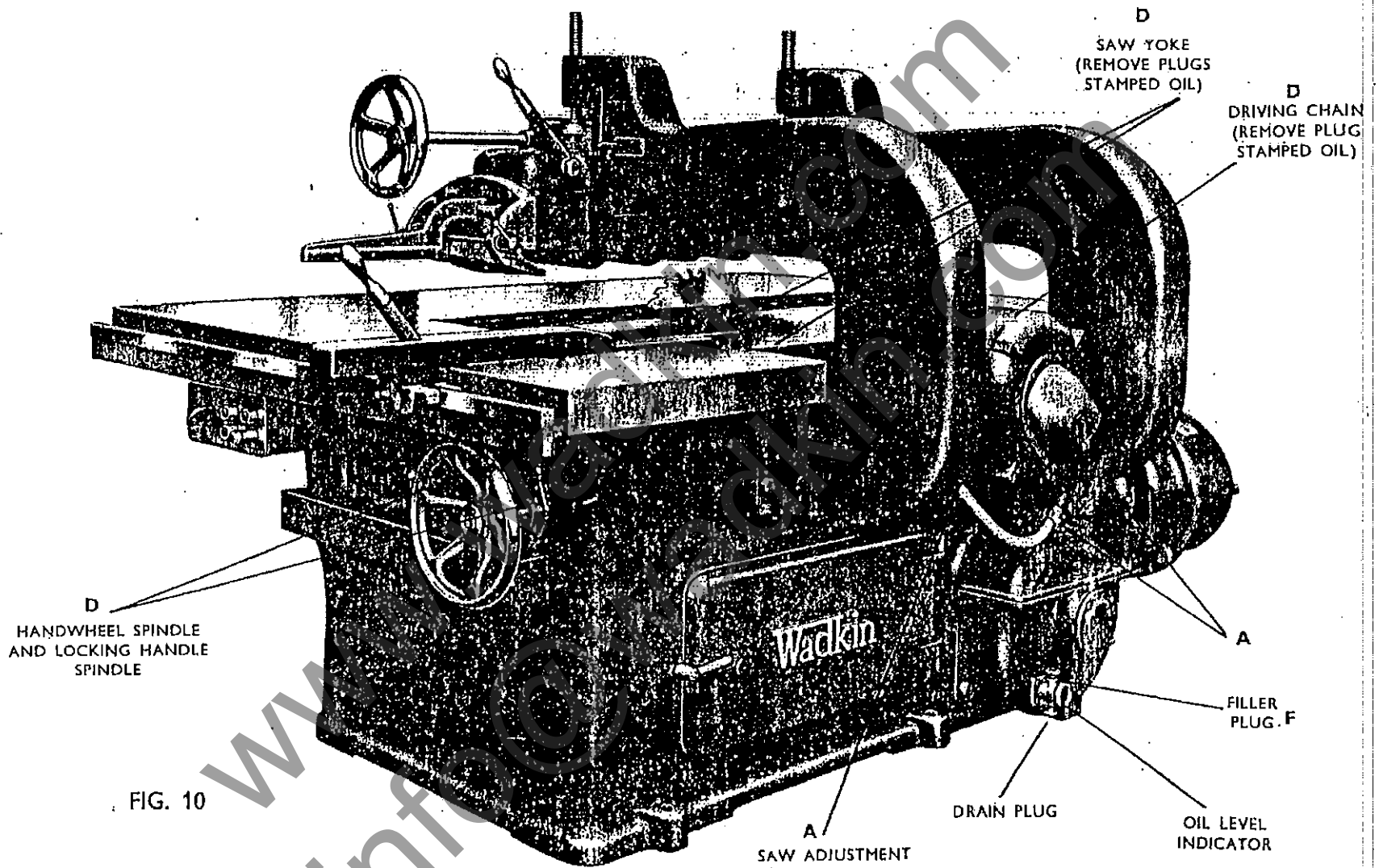

FIG. 10

LUBRICATION (Continued)

LUBRICATION OF BED CHAINS AND SLIDES

These parts are lubricated by the mechanical pump "E" Fig. 9, forcing oil into a felt pad in contact with the sliding surface of the bed chain. Keep the pump filled with a good quality machine oil and check the oil level daily. Set the supply adjusting screws, Fig. 9, just level with the small angle brackets to give suitable lubrication at the highest feed speed; the supply is automatically reduced at lower speeds. Renew the oil pad when necessary. Suitable pads can be obtained from Wadkin Ltd., and should be soaked in oil before fitting.

The capacity of the tank when full is equivalent to approximately two to three weeks' normal running, before it is necessary to refill.

Should it be necessary to stop the action of the pump, the adjusting screws are screwed outwards as far as possible. If, for any reason, the oil sump does not empty when the machine is normally working for a day or two, the pipes from the bottom side of the pump to the felt pad must be disconnected and a piece of wire pushed through to make sure the pipes are not blocked.

GENERAL MAINTENANCE

CLEANLINESS

Clean face of bed chain daily with a wire brush, and remove all dirt and saw dust from the chain and slide; keep the inside of the main frame clean and free from accumulation of saw dust. Use a Wadkin portable electric blower for cleaning the machine down. Wipe pressure beam slides and raising screws weekly. The bed chain slide, lead on quadrants, bed chain sprockets and bed chain should also be thoroughly cleaned every week. Access for blowing out top pressure rollers is provided by a covered hole in top of casting.

MAINTENANCE OF MOTOR SPINDLE BEARINGS

Over lubrication will cause the bearings to overheat and should dismantling of the bearings be necessary the following procedure should be carried out. Clean out the bearings and housings with petrol, and when assembling, pack the bearing and housing half full of new grease, the parts should be kept strictly clean while re-assembling. Fig. 11 shows a section through the saw spindle with the bearing positions and lubrication points clearly marked.

REMOVAL OF REAR SAW COLLAR

To remove rear saw collar 'A' Fig. 11, proceed as follows:—

Unscrew screw 'B', securing front saw collar 'C', by turning in an anti-clockwise direction. Remove collar 'C', saw and cover 'D' at rear of motor. Rotate the spindle in an anti-clockwise direction looking from the front of the machine. At the same time a piece of steel approximately $12" \times 2" \times \frac{1}{4}"$ should be held against the wall of the saw cavity so that the saw peg in the collar 'A' strikes the piece of steel sharply. After two or three such tappings the collar 'A' should be loose enough to be easily UNSCREWED.

NOTE:—Rear saw collar 'A' has left hand fine thread and screw 'B' has left hand Whit. thread.

SECTION THROUGH SAW SPINDLE FOR STANDARD MACHINE WITH 15 H.P. MOTOR

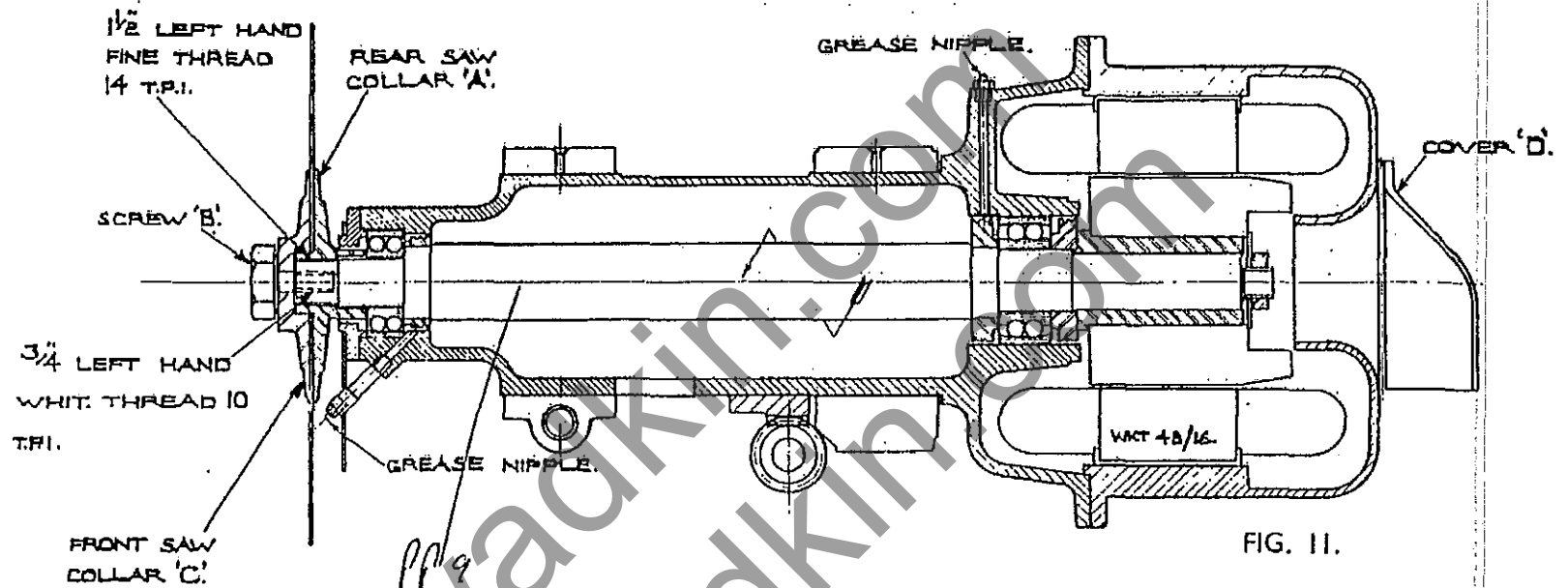

SECTION THROUGH FEED MOTOR SPINDLE

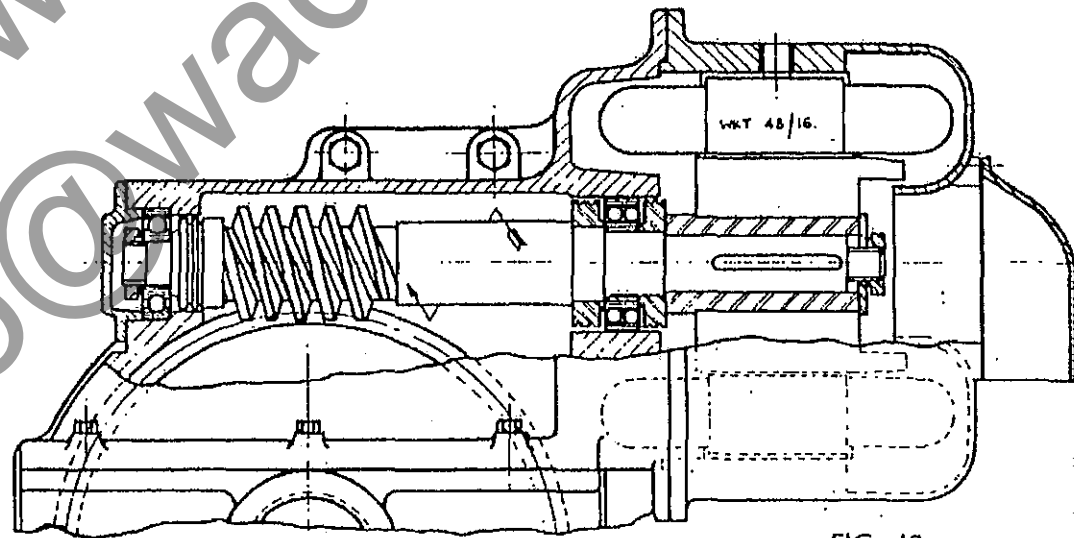

GENERAL MAINTENANCE (Continued)

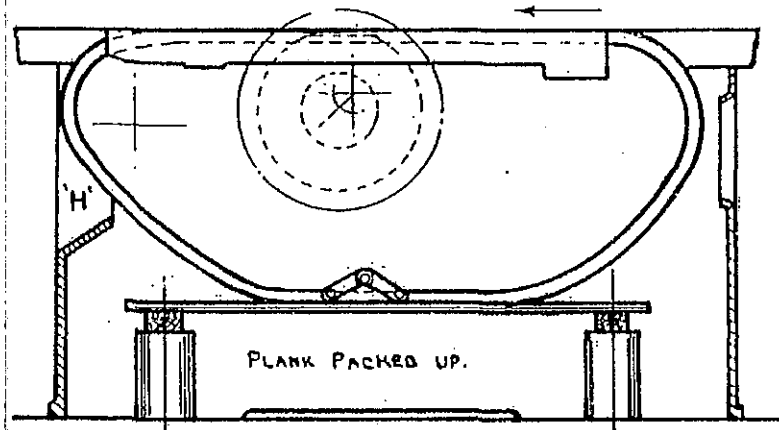

FIG. 13.

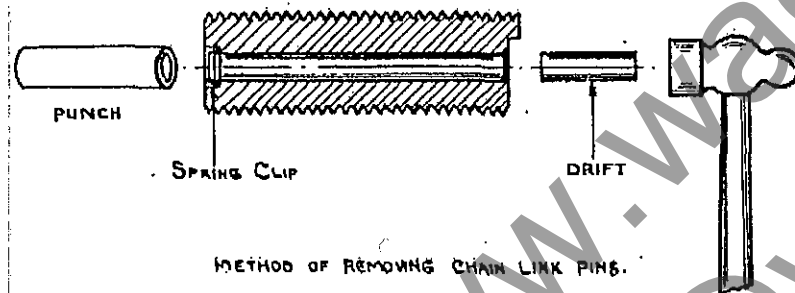

FIG. 14.

IMPORTANT

Do not attempt to twist the chains sideways or serious damage will result. Carry each chain extended on a plank 12' 0" x 9" to prevent any possibility of mishandling. Detach feed drive chain monthly, clean with petrol and soak in warm oil before replacing, also clean the three chain wheels. Clean and adjust the chain driving the mechanical pump, access to the feed and pump chains can be obtained through the door in the rear of the frame.

MAINTENANCE OF FEED CHAIN

To ensure the minimum amount of wear the chain should be detached and cleaned every six months. To detach the chains, slide out the rear safety table, and remove the oil box inside the main frame; insert a plank 4' 0" x 9" x 1" and pack up to take the weight of the chain as shown in Fig. 13. Lift up one chain as shown to expose a link pin, and punch the pin outwards on the end away from the spring clip with the drift, Fig. 14, provided and extract the pin. Repeat with the other chain and then take out chains by lifting rear end through the frame at "H" and pulling along the slides. Take particular care to smear all wearing surfaces and link pins with oil before replacing. On reassembly of the links, insert the pins and drive into the recess of the links the spring clips with the punch supplied.

BEARING LIST

POSITION ON MACHINE	MAKER'S No.	QUANTITY	BORE	OUTSIDE DIAM.	THICKNESS
Saw Spindle (Saw end)	SKF 2308	1	40 m/m	90 m/m	33 m/m
Saw Spindle (Motor end)	SKF 2310	1	50 m/m	110 m/m	40 m/m
Worm Shaft	SKF RMS 11	1	1 1/8"	3 1/2"	1"
Worm Shaft (Motor end) and 2 Worm Wheel Shaft	SKF RM 16	3	2"	4 1/2"	1 1/8"
Feed Chain Driving Shaft	Pollard F 1425	2	2"	3 1/2"	4"
Tail End Bearing on 18 and 25 h.p. Saw Spindles only	SKF RM 12	1	1 1/2"	3 3/4"	1 1/8"

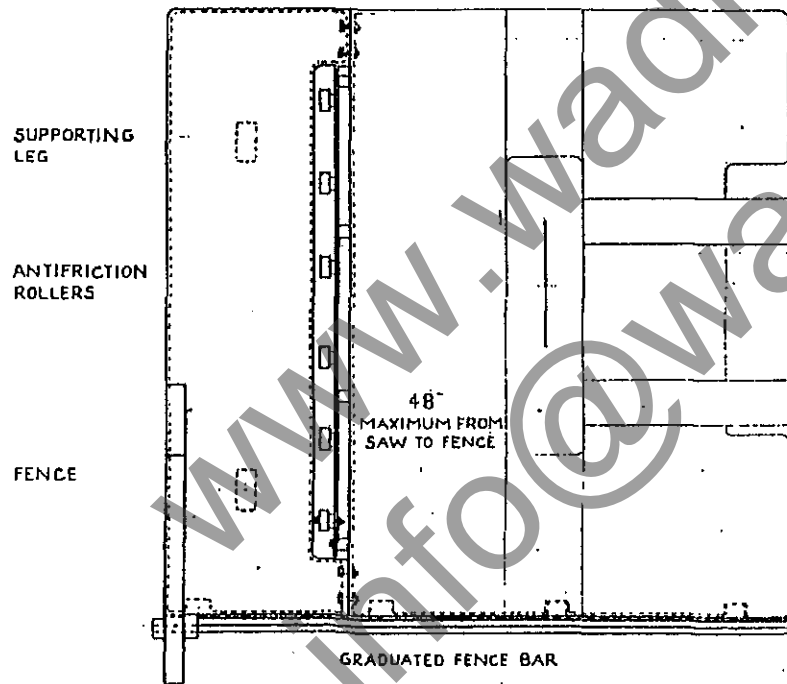

FIG. 15.

EXTENSION TABLE

When the machine is to be used continually for cutting wide plywood sheets, laminated boards, etc., the roller extension table shown in Fig. 15 provides additional support for the boards and prevents the sheets sagging over the normal table edge.

SAW TRUING ATTACHMENT

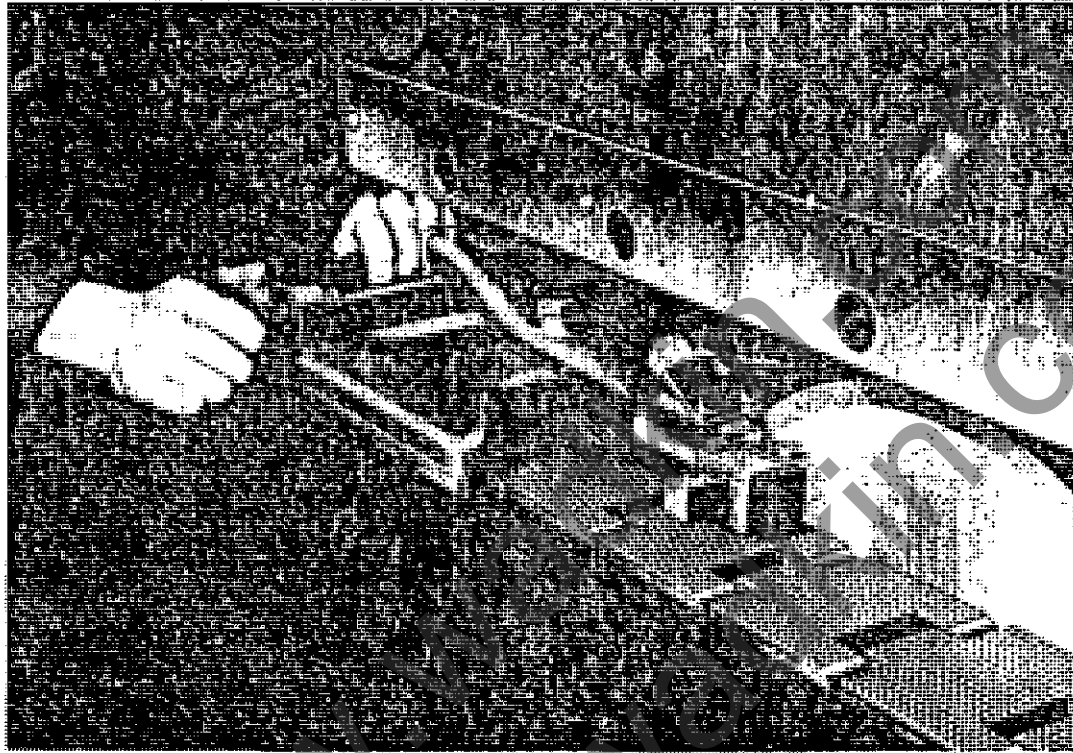

FIG. 16.

The saw truing attachment fits in the slideways between the chainways as shown in Fig. 16. "Ranging down" of the saw is performed by touching the outside diameter of the saw with the centre abrasive stone only. A flat will be left on each tooth with this operation, and the saw should be removed from the machine and each tooth filed until this flat disappears. After this, each tooth should be set to the correct angle with a saw gauge. For all general work the setting as described above will be sufficient, but should a very fine cutting edge be required for glue jointing, etc., the saw teeth should be "side dressed". This is done on the machine using the side stones only in the truing attachment. Care must be taken to remove the minimum amount of metal during this operation.

The abrasive stones used in the attachment are manufactured by the Carborundum Co., Grade 383 (Medium) $\frac{3}{4}$ " square \times 3" long.

SAWS FOR USE ON STRAIGHT LINE EDGER

Use only the best quality saws. They should be perfectly concentric with the bore, which should be a close fit on the spindle nose. All saws should be specially tensioned to run at 3,000 r.p.m. Ensure that the saw collars are kept true and free from burrs.

The following saws are stocked for use on Straight Line Edgers.

STANDARD RIP SAWS FOR GENERAL PURPOSES

Q.S. 16	12" Dia.	12 Gauge
Q.S. 14	15" Dia.	12 Gauge
Q.S. 143	15" Dia.	14 Gauge.
Q.S. 17	17" Dia.	11 Gauge
Q.S. 15	18" Dia.	11 Gauge

THIN GAUGE RIP SAWS

Q.S. 64	14" Dia.	16 Gauge
Q.S. 65	15" Dia.	16 Gauge
Q.S. 66	16" Dia.	16 Gauge

TUNGSTEN CARBIDE TIPPED SAW

Q.S. 17/TC 17" Dia. 5/32" kerf 34 teeth.

PLYWOOD SAW (HOLLOW GROUND) NOVELTY TOOTH

Q.S. 68 12" dia. 12 Gauge at tooth.
Q.S. 91 16" dia. 11 Gauge at tooth.



TOOTH PROFILE, STANDARD RIP SAW.



TOOTH PROFILE, THIN GAUGE RIP SAW.



TOOTH PROFILE, NOVELTY TOOTH.

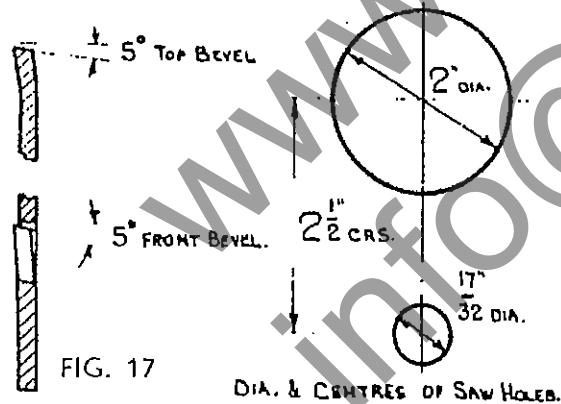

The aim in maintaining straight line edger saws should be to keep the teeth as straight as possible. We recommend a top angle of 5° and a front face angle of 5° as shown in Fig. 17.

The majority of saw failures on this machine are due to excessive bevel. This causes the saw to break down quickly due to the points of the saw teeth collapsing, and causing a rubbing action instead of cutting.

ELECTRICAL INSTRUCTIONS

INSTALLATION

The whole of the cabling between the motors and control gear is carried out by Wadkin Ltd. It is only necessary to bring line cables to the machine for it to be put into service. This should be done as follows :—

1. Fit triple pole isolating switch near the machine, unless this has been supplied to special order by Wadkin Ltd., when it will be fitted and connected up at the machine.
2. Connect the line leads to the appropriate terminals, see diagram D 221/3. The cable should be taken to the machine in steel conduit and secured by locknuts to the entrance shown in Fig. 18. Note access to the control gear is obtained by the door, shown in Fig. 18.
3. Fill the starter with switch oil to the tank level indicated, with the can provided.
4. Connect the machine solidly to earth.
5. When carrying out the operations detailed below, check that the saw motor rotates in the correct direction before starting the feed. If it does not, interchange any two incoming lines. The machine is now ready to start providing the rust preventing grease has been removed and oil levels and lubrication checked.

OPERATING INSTRUCTIONS

1. Close triple pole isolating switch.
2. Select feed speed required by means of speed selector switch at control station, see Fig. 21.
3. Press saw motor start button.
4. After the saw motor is up to speed, press the feed start button.
5. The feed can be stopped independently of the saw.
6. To stop machine, press master stop button.
7. To lock off, use master stop button, press and turn. This renders the start buttons of both saw and feed inoperative for setting up and other purposes.

ELECTRICAL INSTRUCTIONS (Continued)

FAILURE OF SAW TO START

1. Electric supply is not available.
2. Fuses have blown or not fitted.
3. Isolating switch has not been closed.
4. Stop button is locked off.
5. Imperfect connections causing faulty contact.
6. Contacts on automatic starter have moved during transit and require adjusting into position.

FAILURE OF FEED MOTOR TO START

1. Saw is not running. Note the saw is interlocked with the feed and must be running before the feed can be started.
2. The saw starter has not changed over from star to delta. Attend to timing device.
3. Imperfect connection causing faulty contact.
4. Contacts on automatic starter have moved during transit or connecting up and require adjusting into position.

SHUT DOWN WHILST OPERATING AND FAILURE TO RESTART

1. Fuses have blown.
2. Overloads have tripped. They will reset automatically after a short time, and machine can be restarted in the usual manner.

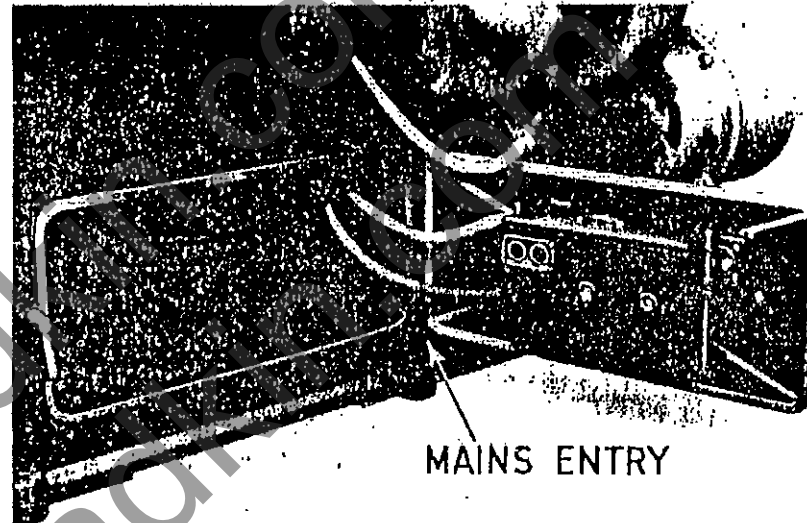

FIG. 18.

ELECTRICAL INSTRUCTIONS (Continued)

MAINTENANCE

1. Change the switch oil twice a year. Use class B switch oil B.S.S. 148.
2. Change the fixed and moving contacts every two years. Do not file contacts. See Figs. 19 and 20.
3. Blow motor down weekly with electric blower.
4. Check earth connection from time to time.

ADJUSTMENTS

1. OVERLOAD settings can be varied by means of adjustment pointers provided. This is normally done by Wadkin Ltd., but if the setting is found to be too fine for the work normally done on the machine, the setting can be increased.
2. TIMING DEVICE on saw starter. To reduce the time of change over from the star to delta, screw down the red knob at starter.

GENERAL. Users are recommended to display in an appropriate position in maintenance department, Wadkin Electrical Maintenance Instruction Card No. 356, which is issued gratis on application.

CONTACTS

Showing method of removal.

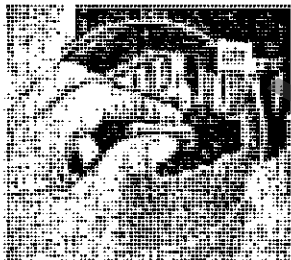

FIG. 19.

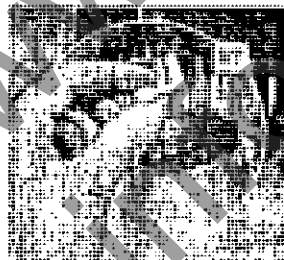

FIG. 20.

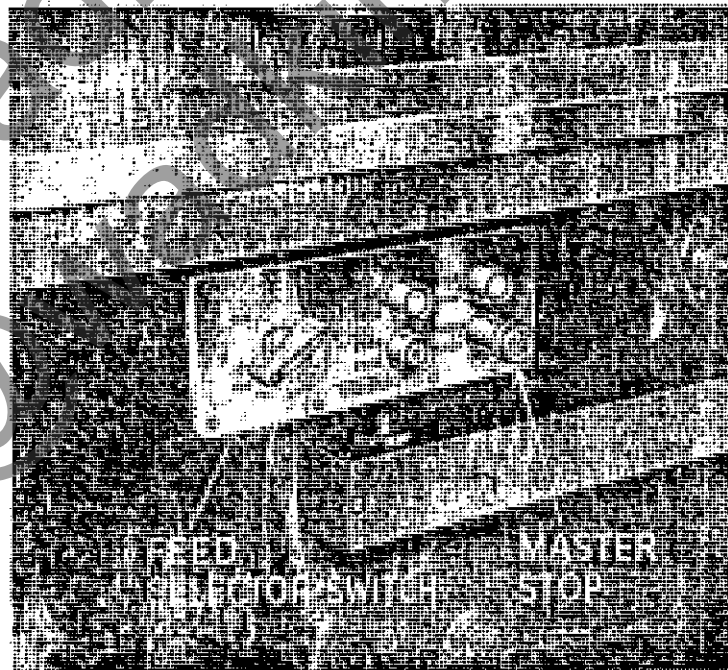
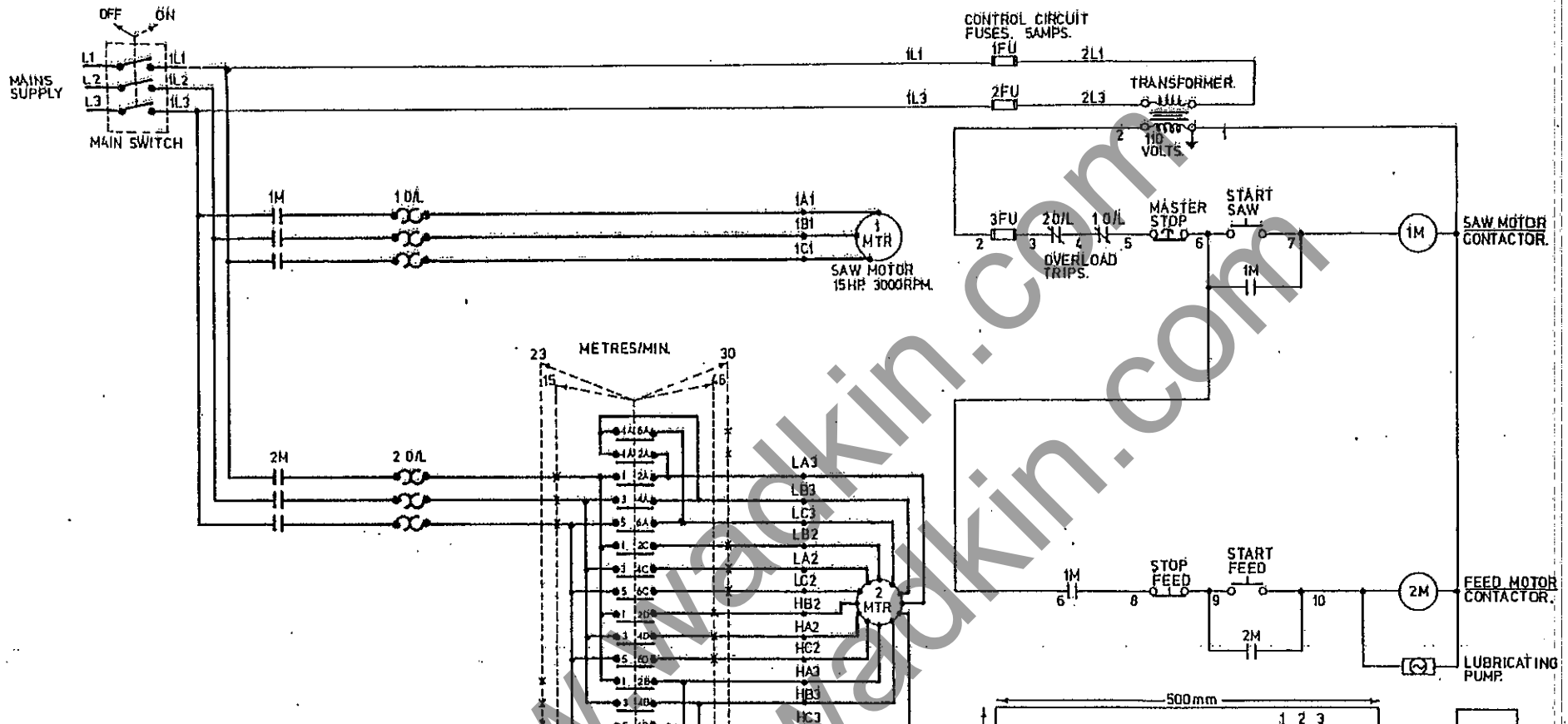

FIG. 21.



OPERATING INSTRUCTIONS.

1. TO START MACHINE. PRESS 'START SAW' PUSHBUTTON.
 2. SELECT FEED SPEED AND PRESS 'START FEED' PUSHBUTTON.
 3. TO STOP FEED. PRESS 'STOP FEED' PUSHBUTTON.
 4. TO STOP MACHINE. PRESS 'MASTER STOP' PUSHBUTTON.
- NOTE: FEED WILL NOT START UNTIL SAW MOTOR IS STARTED AND ATTAINED FULL SPEED.

FEED SPEED SELECTOR SWITCH
ref. T2b-8-104/a FS GB 141672.

FEED MOTOR
3/2/1.5/1 HP
1500/1000/
750/500RPM.

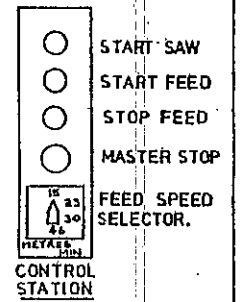
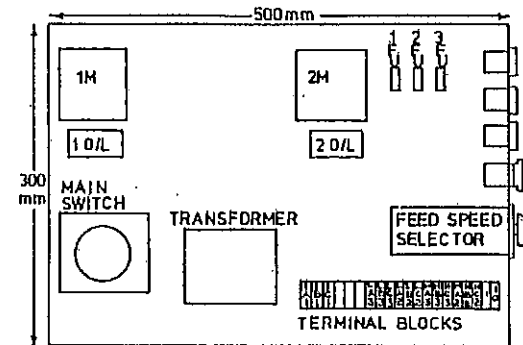
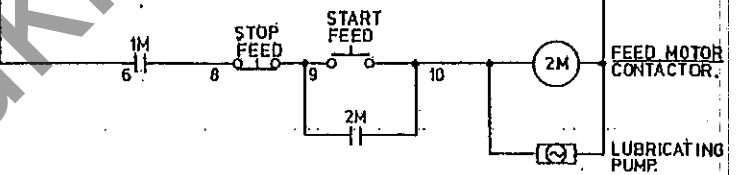

SIMILAR ID

THIRD ANGLE PROJECTION **WADKIN LTD. LEICESTER**

SURFACE FINISH	IMPERIAL LIMITS		DATE	SIC	F	E	D	C	B	A	DESCRIPTION	QTY.	MATERIAL
	FRACTIONS	DECIMALS											
V - ROUGH M/C	1/16	0.005									STRAIGHT LINE EDGER MODEL PU. D.O.L.		PART No. D. 2259
VV - FINISH M/C	1/32	0.0025											
VVV - ROUGH GRIND	1/64	0.00125											
VVVV - FINISH GRIND	1/128	0.000625											

DATE: 29-9-76 FORMED BY: JWD CHECKED BY: JWB

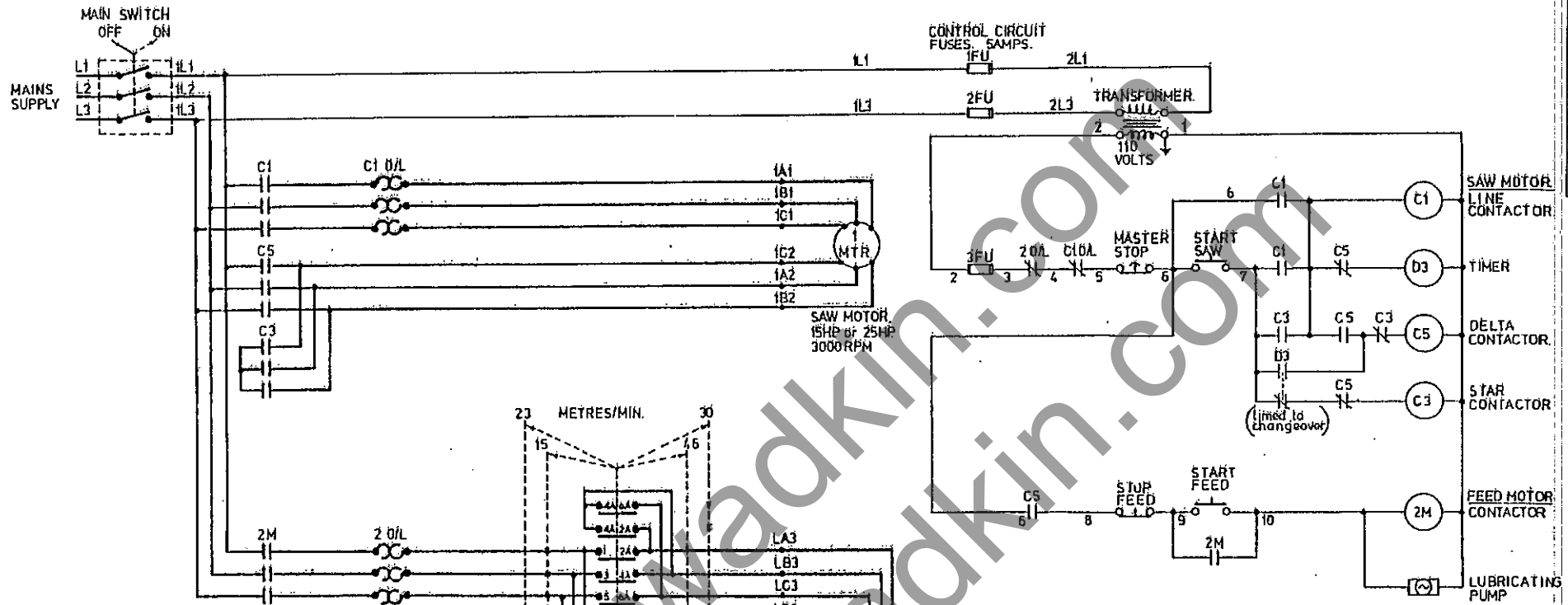

OPERATING INSTRUCTIONS

- 1 TO START MACHINE, PRESS 'START SAW' PUSHBUTTON.
- 2 SELECT FEED SPEED AND PRESS 'START FEED' PUSHBUTTON.
- 3 TO STOP FEED, PRESS 'STOP FEED' PUSHBUTTON.
4. TO STOP MACHINE, PRESS 'MASTER STOP' PUSHBUTTON.

note: FEED WILL NOT START UNTIL SAW MOTOR IS STARTED AND ATTAINED FULL SPEED.

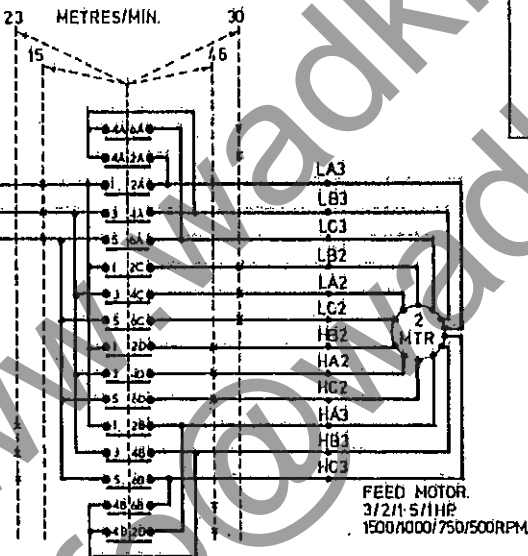

FEED SPEED SELECTOR SWITCH.
ref. T26-B-184 & FSG B141672.

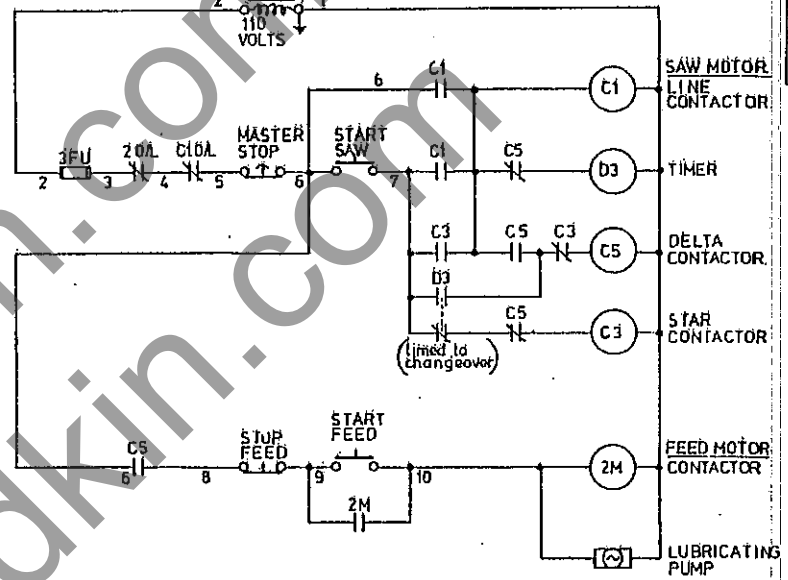

CONTROL PANEL LAYOUT

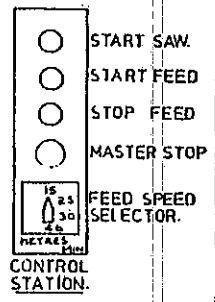

SURFACE FINISH	
V	ROUGH M/C
VV	FINISH M/C
VVV	ROUGH GRIND
VVVV	FINISH GRIND

IMPERIAL LIMITS		METRIC LIMITS	
FRACTIONS	F	WHOLE NUMBERS	M
DECIMALS	DOS	DECIMALS	MM
		DIAL READING LIMITS	SEE 6351

DATE	SIG	F	E	D	C	B	A
30-11-77							

THIRD ANGLE PROJECTION

CONTROL CIRCUIT CABLES MARKINGS ALTERED

WADKIN LTD. LEICESTER

DESCRIPTION
STRAIGHT LINE EDGER
MODEL PU. Y.D.

MATERIAL

PART NO.
D. 2258

SEE DIAGRAMS D.2258 & D.2259

RETAIN THIS DIAGRAM FOR FUTURE REFERENCE.

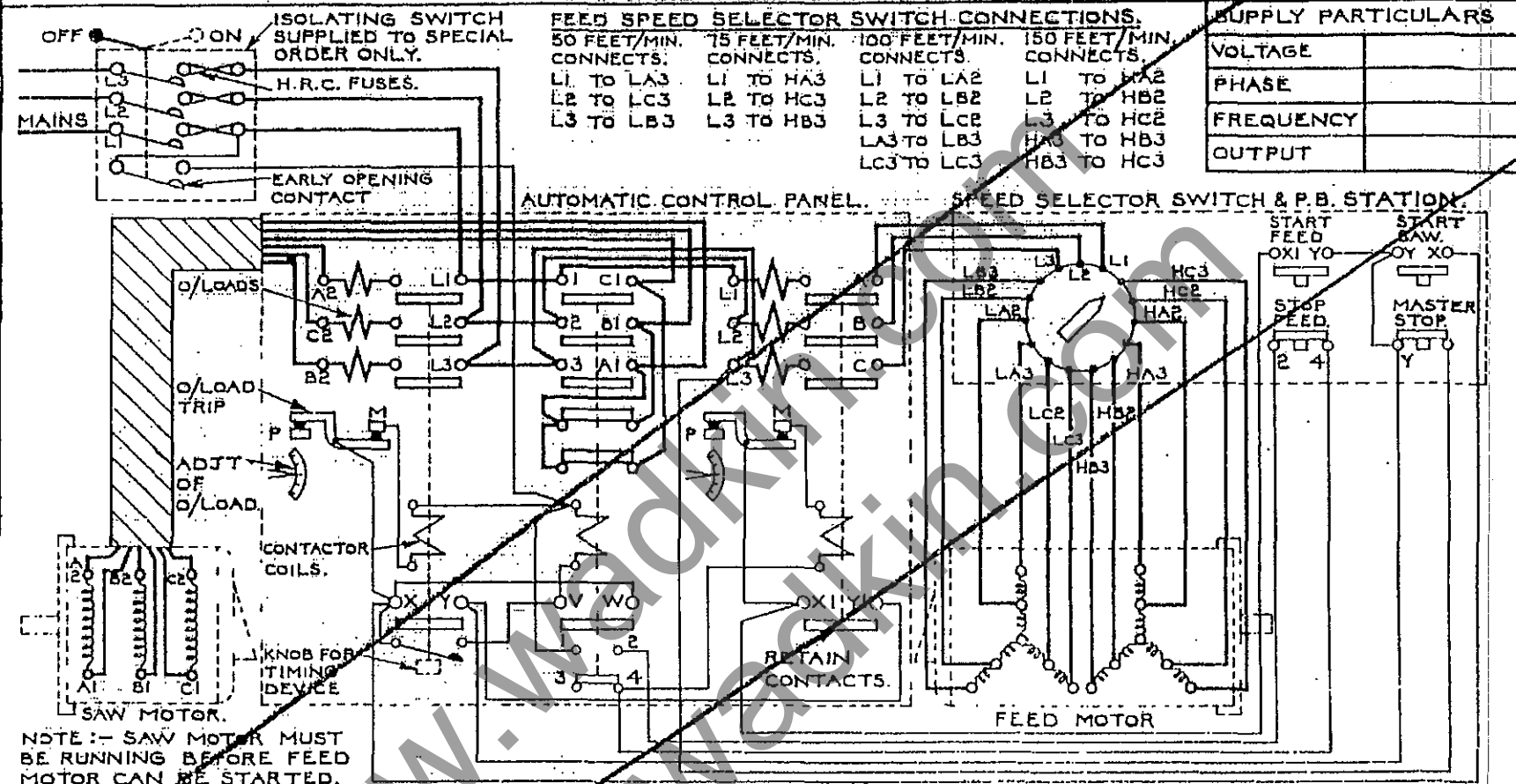

SUPPLY PARTICULARS	
VOLTAGE	
PHASE	
FREQUENCY	
OUTPUT	

NOTE :- SAW MOTOR MUST BE RUNNING BEFORE FEED MOTOR CAN BE STARTED.

INSTALLATION INSTRUCTIONS. FIT TRIPLE POLE ISOLATING SWITCH NEAR MACHINE UNLESS SUPPLIED BY WADKIN LTD. TO SPECIAL ORDER, SO THAT THE ELECTRICAL GEAR MAY READILY BE ISOLATED FOR INSPECTION PURPOSES. BRING LINE CABLES TO ISOLATING SWITCH AND TO L1 - L2 - L3 AT CONTACTOR THROUGH CONDUIT WHICH SHOULD BE SECURED TO THE APPARATUS BY MEANS OF LOCKNUTS. FILL STARTER TANK TO INDICATED LEVEL WITH OIL PROVIDED. ENSURE THAT THE DIRECTION OF ROTATION IS CORRECT BEFORE PUTTING MACHINE INTO SERVICE. TO REVERSE ROTATION INTERCHANGE L1 AND L2 AT CONTACTOR.

OVERLOAD. THE SETTING OF THE OVERLOADS MAY BE VARIED BY MEANS OF THE ADJUSTMENT POINTERS, NORMAL SETTING IS TO THE MARKS CORRESPONDING TO THE FULL LOAD MOTOR CURRENTS. SHOULD THE MOTORS STOP DUE TO OVERLOAD WAIT FOR A SHORT TIME TO ALLOW THE OVERLOADS TO COOL, THEN START IN THE USUAL MANNER.

ADJUSTMENT OF TIMING DEVICE. SHOULD THE CONTACTOR CHANGE OVER FROM 'STAR' TO 'DELTA' BEFORE THE MOTOR IS UP TO SPEED, TURN THE RED ADJUSTING KNOB IN ANTICLOCKWISE DIRECTION, & VICE-VERSA TO DECREASE THE TIME.

MASTER STOP BUTTON. THIS IS FITTED WITH A 'LOCKOFF' FEATURE & MUST BE RELEASED BEFORE A START CAN BE MADE.

MAINTENANCE. 1. RENEW OIL YEARLY. 2. RENEW CONTACTS AND SPRINGS EVERY TWO YEARS.

WADKIN LTD.
LEICESTER.

DIAGRAM OF CONNECTIONS.

D. 221/3.



... blow away harmful dust,
chips and dirt with a
Wadkin Electric Blower

No motor can run at its maximum efficiency with its ventilating duct or control gear covered with dust and dirt. Sooner or later the resultant overheating will cause serious trouble.

Similarly, accumulations of chips and dust, in the mechanical parts of the machine can interfere with its efficiency. A few minutes a week for blowing down all Woodworking Machinery will be amply repaid in better and easier running, in increased life, and freedom from breakdown.

Blowers can be supplied for single phase A.C. or Direct Current for any voltage up to 250.

Please state voltage when ordering.





SPARE PARTS BOOKLET

CONTENTS

1. Basic ordering requirements.
2. Sample type order.
3. List of item numbers and description of item.
4. Drawing showing item numbers.

PUA

STRAIGHT LINE EDGER

www.wadkin.com
info@wadkin.com

PU461/1/9/A	BALL BEARING LOCKNUT
PU461/1/9/B	BALL BEARING LOCKNUT
PU461/1/13	COLLAR
PU461/1/F.18425	POLLARD BEARING
PU461/1/MJ15	TIGHTENER SPROCKET
PU461/1/SKF R.M.16	SKEFCO BEARING
PU461/1/W.450 35050/R4	WESTON OIL SEAL
PU461/1/110088	RENOLD CHAIN 60" PITCH
PU461/1/YZ.18B	CONTROL BOX
PU461/1/JT150	KNOB FOR CLAMP PLATE
PU461/2/PU3	LEFT HAND TABLE
PU461/2/PU9/A	SAW GAP DOOR
PU461/2/PU22B	WORMWHEEL HOUSING FOR FEED GEARCASE
PU461/2/PU23A	WORM HOUSING FOR FEED GEARCASE
PU461/2/PU24	STATOR FRAME FOR FEED MOTOR
PU461/2/PU26	COVER FOR LUBRICATOR PUMP DRIVE
PU461/2/PU33	SPIRAL GEAR HOUSING FOR PRESSURE BAR
PU461/2/PU42/A	DOOR FOR REAR OF FRAME
PU461/2/PU43	YOKE FOR SAW SPINDLE BARREL
PU461/2/PU44	SAW SPINDLE BARREL
PU461/2/PU45	STATOR FRAME FOR SAW MOTOR
PU461/2/PU46	END COVER FOR SAW BEARING
PU461/2/PU47	WORMWHEEL SEGMENT FOR ADJUSTING SCREW
PU461/2/PU48	BRACKET FOR SAW ADJUSTING WORM SHAFT
PU461/2/PU53	FEED CHAIN LUBRICATOR BOX
PU461/2/PU54	BRACKET FOR LUBRICATOR BOX
PU461/2/PU55	END COVER FOR FEED AND FEED MOTOR SHAFTS
PU461/2/PU56	END COVER FOR WORMWHEEL SHAFTS

PU SPARE PARTS LIST

PU461/1/PU4	FRONT TABLE SECTION
PU461/1/PU5	SLIDING REAR TABLE SECTION
PU461/1/PU6	R.H. SLIDE FOR REAR TABLE
PU461/1/PU7	L.H. SLIDE FOR REAR TABLE
PU461/1/PU10/A	CHAIN SLIDE
PU461/1/PU11L	CHAIN SLIDE SEGMENT L.H. SIDE
PU461/1/PU11R	CHAIN SLIDE SEGMENT R.H. SIDE
PU461/1/PU12A	LEAD ON BRACKET
PU461/1/PU13L	LINK FOR FEED CHAIN L.H. CHAIN
PU461/1/PU13R	LINK FOR FEED CHAIN R.H. CHAIN
PU461/1/PU14	FEED CHAIN SPROCKET
PU461/1/PU15L	HOUSING FOR DRIVE SHAFT BEARING L.H. SIDE
PU461/1/PU15R	HOUSING FOR DRIVE SHAFT BEARING R.H. SIDE
PU461/1/PU17	GEARBOX SPROCKET
PU461/1/PU18	DRIVE SHAFT SPROCKET 23T
PU461/1/PU20	BRACKET FOR SAW ADJ. AND LOCKING SHAFTS
PU461/1/PU21	WORMWHEEL FOR FEED GEARS
PU461/1/PU28	NUT FOR PRESSURE BAR
PU461/1/PU36	SLIDE CLAMP FOR PRESSURE BAR
PU461/1/PU37	LEVER FOR SLIDE CLAMP
PU461/1/PU38	HAND LEVER FOR SLIDE CLAMP
PU461/1/PU49/A	BRACKET FOR SAW ADJUSTING WORMSHAFT
PU461/1/PU51	FENCE LOCKING HAND CAM
PU461/1/PU52	FENCE LOCKING LEVER
PU461/1/PU55	END COVER FOR FEED AND FEED MOTOR SHAFTS
PU461/1/PU65	BUSH FOR CHAIN SLIDE SLEEVE
PU461/1/PU76	PRESSURE BAR
PU461/1/PU79A	FIRST WIDE PRESSURE ROLLER SWING
PU461/1/PU81/A	NARROW PRESSURE ROLLER SWING

PU461/1/PU82	SIGHTING BAR
PU461/1/PU83	WIDE PRESSURE ROLLER
PU461/1/PU84	NARROW PRESSURE ROLLER
PU461/1/PU110	PIN FOR FENCE LEVERS
PU461/1/PU111	LOCKING PAD FOR FENCE
PU461/1/PU112	SPRING FOR REAR TABLE SECTION
PU461/1/PU114	WORMWHEEL SHAFT FOR FEED GEAR CASE
PU641/1/PU117	DISTANCE COLLAR FOR WORMWHEEL SHAFT
PU461/1/PU118	SCREW FOR PUMP DRIVE CHAINWHEEL
PU461/1/PU119	LUBRICATOR PUMP DRIVE CHAINWHEEL
PU461/1/PU123	GREASE PIPE FOR CHAIN TIGHTENER SPROCKET
PU461/1/PU124	FEED DRIVE SHAFT
PU461/1/PU125	PIVOT FOR SIGHTING BAR
PU461/1/PU126	PLATE FOR DEPTH RULE
PU461/1/PU129	LINK FOR LOCKING SLIDE
PU461/1/PU131	PIVOT SCREW FOR LOCKING LEVER
PU461/1/PU132	PRESSURE SCREW FOR SLIDE CLAMP
PU461/1/PU133	FULCRUM STUD FOR SLIDE CLAMP
PU461/1/PU134/A	SHAFT FOR ADJUSTING PRESSURE
PU461/1/PU142	PIN FOR FEED CHAIN LINKS
PU461/1/PU143	SPRING CIRCLIP FOR FEED CHAIN LINKS
PU461/1/PU144	REAR BOLT FOR CHAIN SLIDE
PU461/1/PU145	REAR SLEEVE FOR CHAIN SLIDE
PU461/1/PU146	REAR NUT FOR CHAIN SLIDE
PU461/1/PU147	FRONT BOLT FOR CHAIN SLIDE
PU461/1/PU148	FRONT SLEEVE FOR CHAIN SLIDE
PU461/1/PU149	FRONT NUT FOR CHAIN SLIDE
PU461/1/PU150	SPIRAL PINION FOR ADJUSTING PRESSURE
PU461/1/PU157	PLATE FOR LUBRICATOR PAD
PU461/1/PU176	FRONT COVER FOR CHAIN
PU461/1/PU177	REAR COVER FOR CHAIN

PU461/1/PU178	STRAP
PU461/1/PU184	PIVOT BUSH
PU461/1/PU185	BUSH FOR NARROW ROLLERS
PU461/1/PU186	BUSH FOR WIDE ROLLERS
PU461/1/PU187/A	SHORT SHAFT FOR PRESSURE ROLLERS
PU461/1/PU188	LONG SHAFT FOR PRESSURE ROLLERS
PU461/1/PU189	LONG PRESSURE ROLLER SWING PIN
PU461/1/PU190	SHORT PRESSURE ROLLER SWING PIN
PU461/1/PU191	WEAR STRIP FOR FRONT PRESSURE SLIDE
PU461/1/PU192	STRIP FOR FRONT PRESSURE SLIDE
PU461/1/PU193	STRIP FOR REAR PRESSURE SLIDE
PU461/1/PU194	RUBBER SLEEVE FOR PRESSURE SWING
PU461/1/PU197	FRONT PLATE FOR PRESSURE BAR
PU461/1/PU240/A	FINGER PLATE BRACKET
PU461/1/PU244	STOP ROD FOR FINGERS
PU461/1/PU255	EXTENSION PLATE FOR FENCE
PU461/1/PU267	OUTER FEED STOP
PU461/1/PU268	PRESSURE SPRINGS
PU461/1/PU271	LONG PRESSURE ROLLER SWING PIN
PU461/1/PU274	MAIN FRAME
PU461/1/PU296	BUSH FOR CHAIN TIGHTENER SPROCKET
PU461/1/PU298	GUIDE STRIP FOR TEE BOLT
PU461/1/PU299	TEE BOLT FOR CHAIN TIGHTENER
PU461/1/PU300	SPACING WASHER FOR OIL SEAL
PU461/1/PU393	INSIDE GUARD FOR LUBRICATING PUMP DRIVE
PU461/1/PU480	SPACE SLEEVE FOR WORMWHEEL SHAFT
PU461/1/2/A	FORM HANDLE
PU461/1/4B	HANDWHEEL
PU461/1/4C	TWO BALL HANDLE
PU461/1/5	COLLAR

PU461/2/OA

CLAMP NUT FOR LEVER

PU461/2/PR428

FAN

PU461/2/PR429

AIR SHIELD

PU461/2/QV9

OIL FILLER INDICATOR

PU461/2/QV10

COVER FOR OIL DRAIN

PU461/2/RM81

POINTER

PU461/2/SKF2308

BEARING

PU461/2/SKF2310

BEARING

PU461/2/SKF RM12

BEARING

PU461/2/SKF RM16

BEARING

PU461/2/SKF RMS11

BEARING

PU461/2/SSR101

SCALED RULE

www.wadkin.com
info@wadkin.com

PU461/2/PU62	R.H. TABLE
PU461/2/PU63	FENCE RAIL
PU461/2/PU77L	PRESSURE BAR L.H.
PU461/2/PU77R	PRESSURE BAR R.H.
PU461/2/PU100	SAW SPINDLE
PU461/2/PU101	SCREW FOR SAW SPINDLE END
PU461/2/PU102	FRONT SAW COLLAR
PU461/2/PU103	REAR SAW COLLAR
PU461/2/PU104	WASHER FOR ROTORS
PU461/2/PU105	LOCKING SHAFT FOR SAW BARREL
PU461/2/PU106	ADJ. SHAFT FOR SAW BARREL
PU461/2/PU107	WORM SHAFT FOR SAW BARREL
PU461/2/PU108	GREASE PIPE FOR SAW BEARING
PU461/2/PU113	WORM SHAFT FOR FEED GEAR CASE
PU461/2/PU115	SLEEVE FOR FEED MOTOR ROTOR
PU461/2/PU116	SLEEVE FOR SAW MOTOR ROTOR
PU461/2/PU119	LUBRICATOR PUMP DRIVE CHAINWHEEL
PU461/2/PU126	PLATE FOR DEPTH RULE
PU461/2/PU130	SCREW FOR LOCKING LINK
PU461/2/PU135	SCREW FOR ADJUSTING PRESSURE
PU461/2/PU150	SPIRAL PINION FOR ADJUSTING PRESSURE
PU461/2/PU153	SAW BEARING GREASE RETAINER
PU461/2/PU154	REAR BEARING GREASE RETAINER
PU461/2/PU158	GREASE RETAINER FOR WORMWHEEL SHAFT
PU461/2/PU164	DUST GUARD FOR SAW BARREL
PU461/2/PU243	LINK
PU461/2/PU245	PIVOT ROD FOR FINGERS
PU461/2/PU247/A	STATOR FRAME
PU461/2/PU248	SAW SPINDLE
PU461/2/PU249	SLEEVE FOR SAW MOTOR ROTOR
PU461/2/PU250	GREASE RETAINER FOR SAW SPINDLE
PU461/2/PU251	GREASE RETAINER FOR SAW SPINDLE

PU461/2/PU252	SUPPORT FOR GUARD
PU461/2/PU258	SLEEVE FOR SAW MOTOR ROTOR
PU461/2/PU264	DISTANCE SLEEVE
PU461/2/PU266	FINGER
PU461/2/PU294	VENTILATION COWL FOR FEED MOTOR
PU461/2/PU295	VENTILATION COWL FOR SAW MOTOR
PU461/2/PU306	LUBRICATING PUMP CHAIN WHEEL $\frac{5}{8}$ " BORE
PU461/2/PU316	BRACKET FOR LUBRICATING PUMP
PU461/2/PU476	SPEC. SLEEVE FOR SAW MOTOR
PU461/2/PU477	COLLAR
PU461/2/PU489	COVER FOR SAW SPINDLE BARREL
PU461/2/PU491	SPIRAL GEAR FOR ADJUSTING PRESSURE
PU461/2/PU534	FILLING IN PIECE FOR DOOR

PU461/2/1	DOOR KNOB
PU461/2/1A	BALL BEARING LOCKNUT
PU461/2/1A	DOOR HANDLE
PU461/2/1B	BALL BEARING LOCKNUT
PU461/2/1B	DOOR HINGE
PU461/2/4A	BALL BEARING LOCKNUT
PU461/2/4A	COLLAR
PU461/2/5A	BALL BEARING LOCKNUT
PU461/2/5A	HANDWHEEL
PU461/2/53	GREASE RETAINER
PU461/2/110	GREASE RETAINER

PU461/2/111059	RENOLD CHAIN $\frac{5}{8}$ " PITCH
PU461/2/LS162	PIN FOR DOOR HINGE

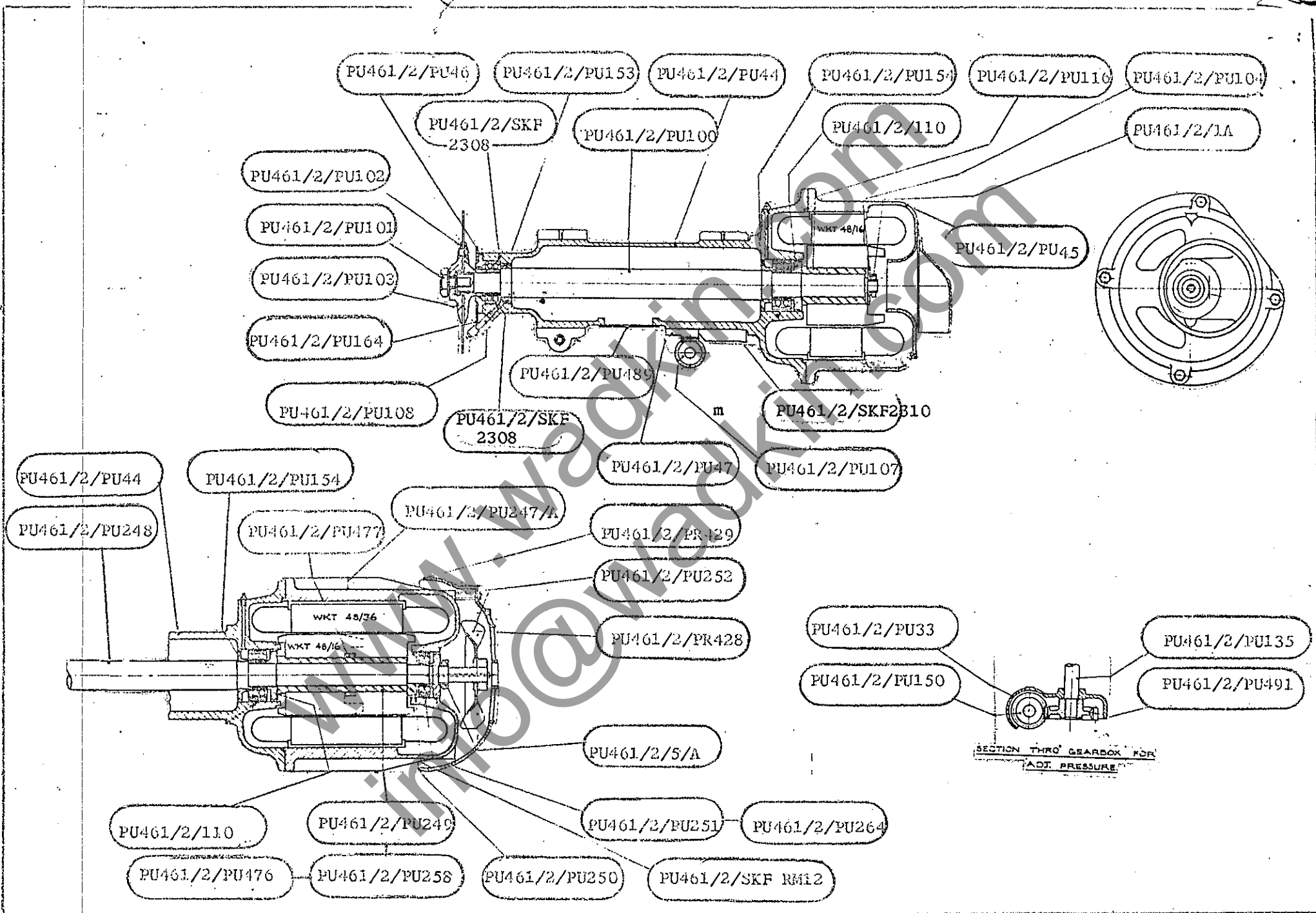

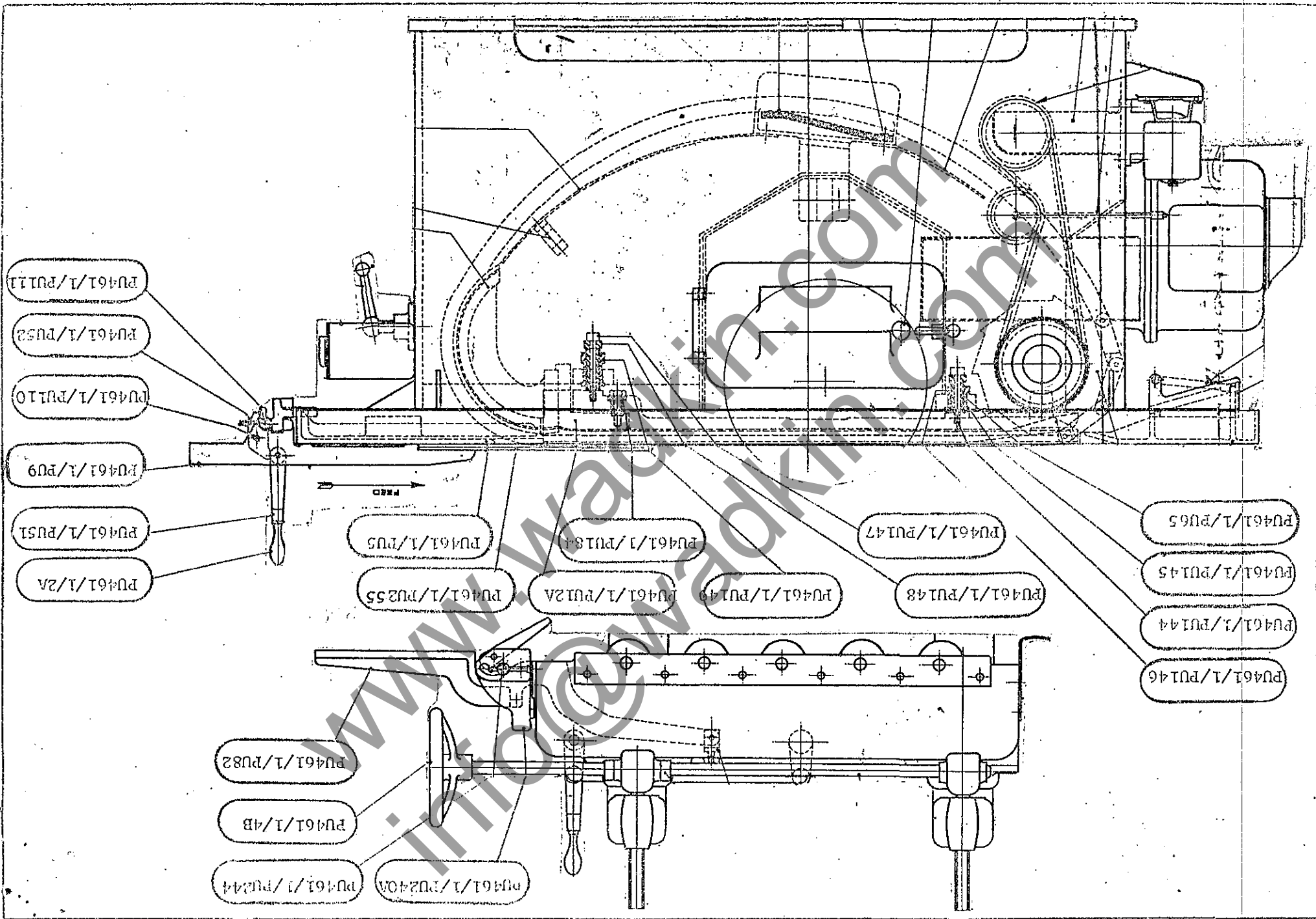

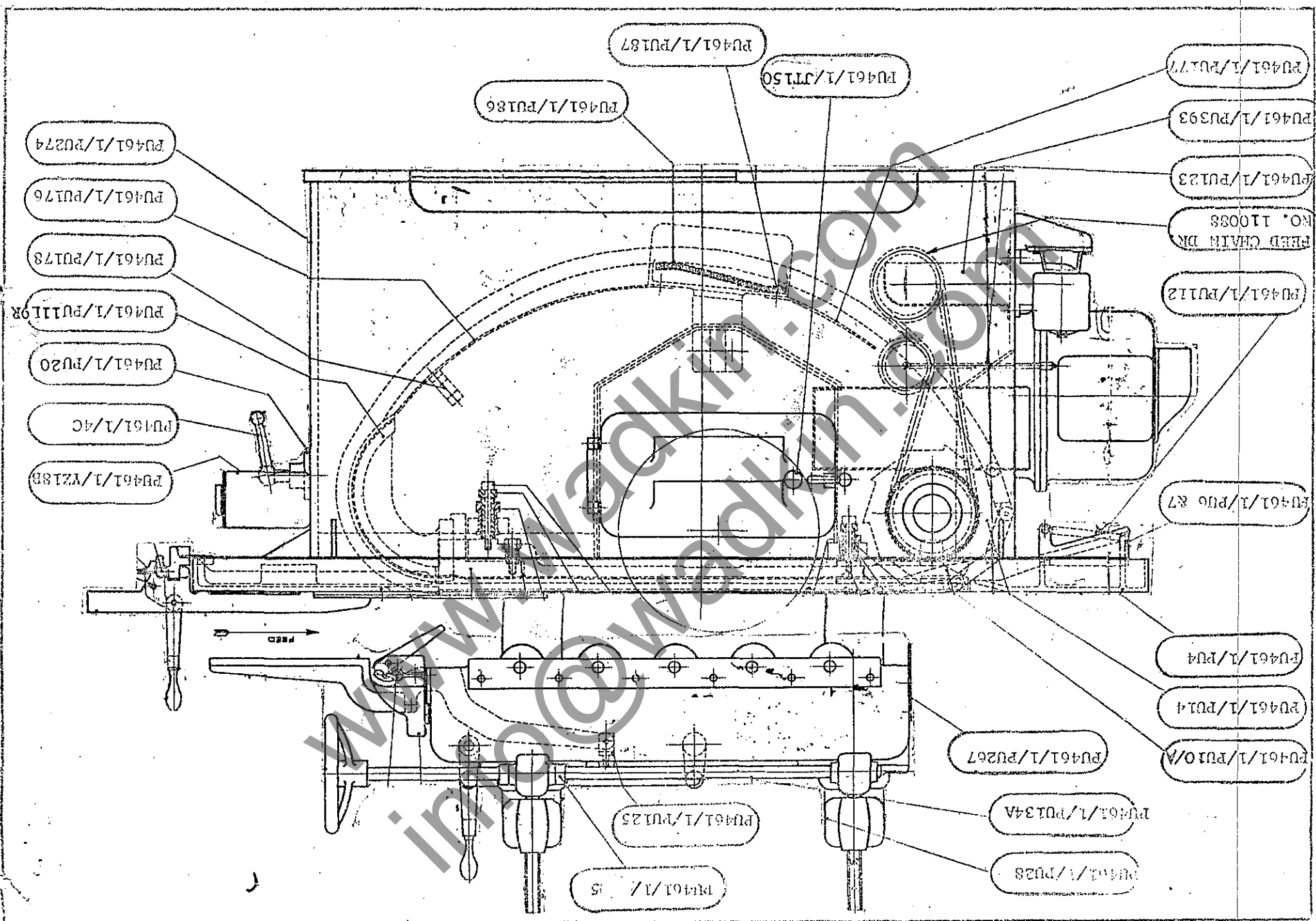

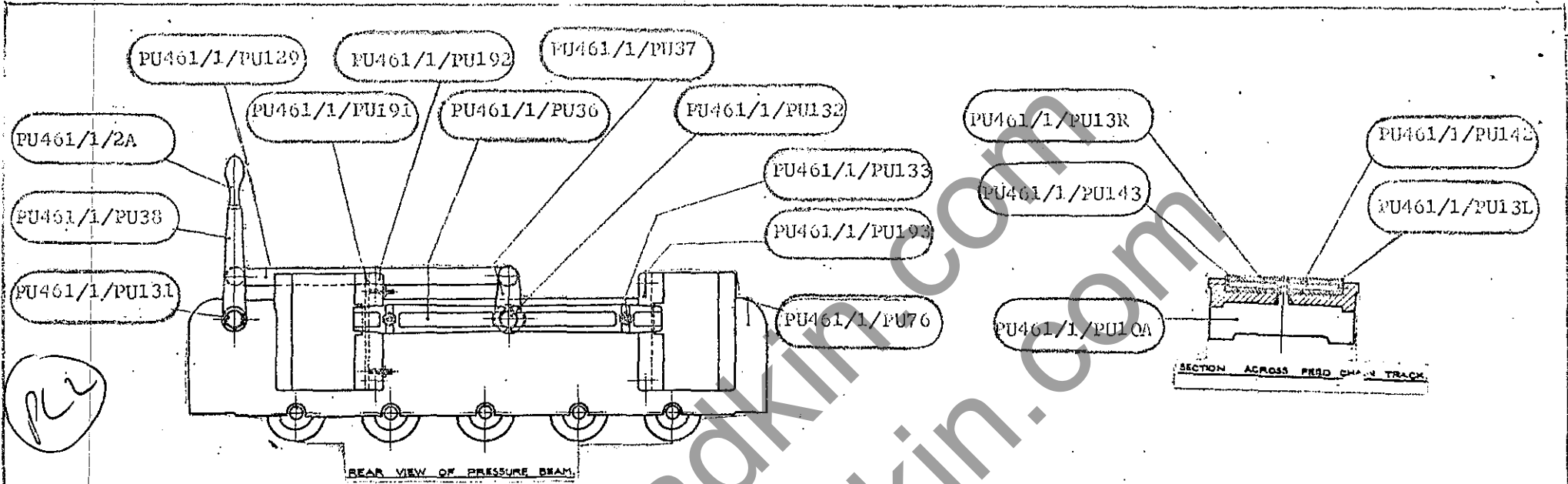

PC

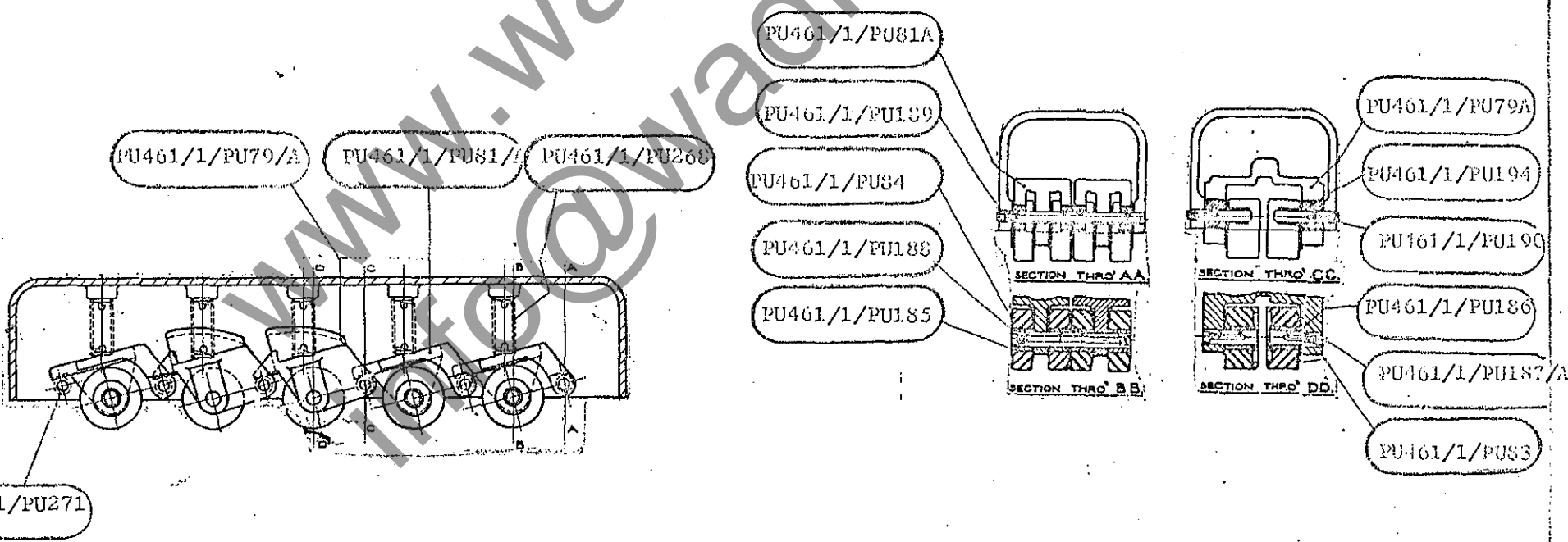

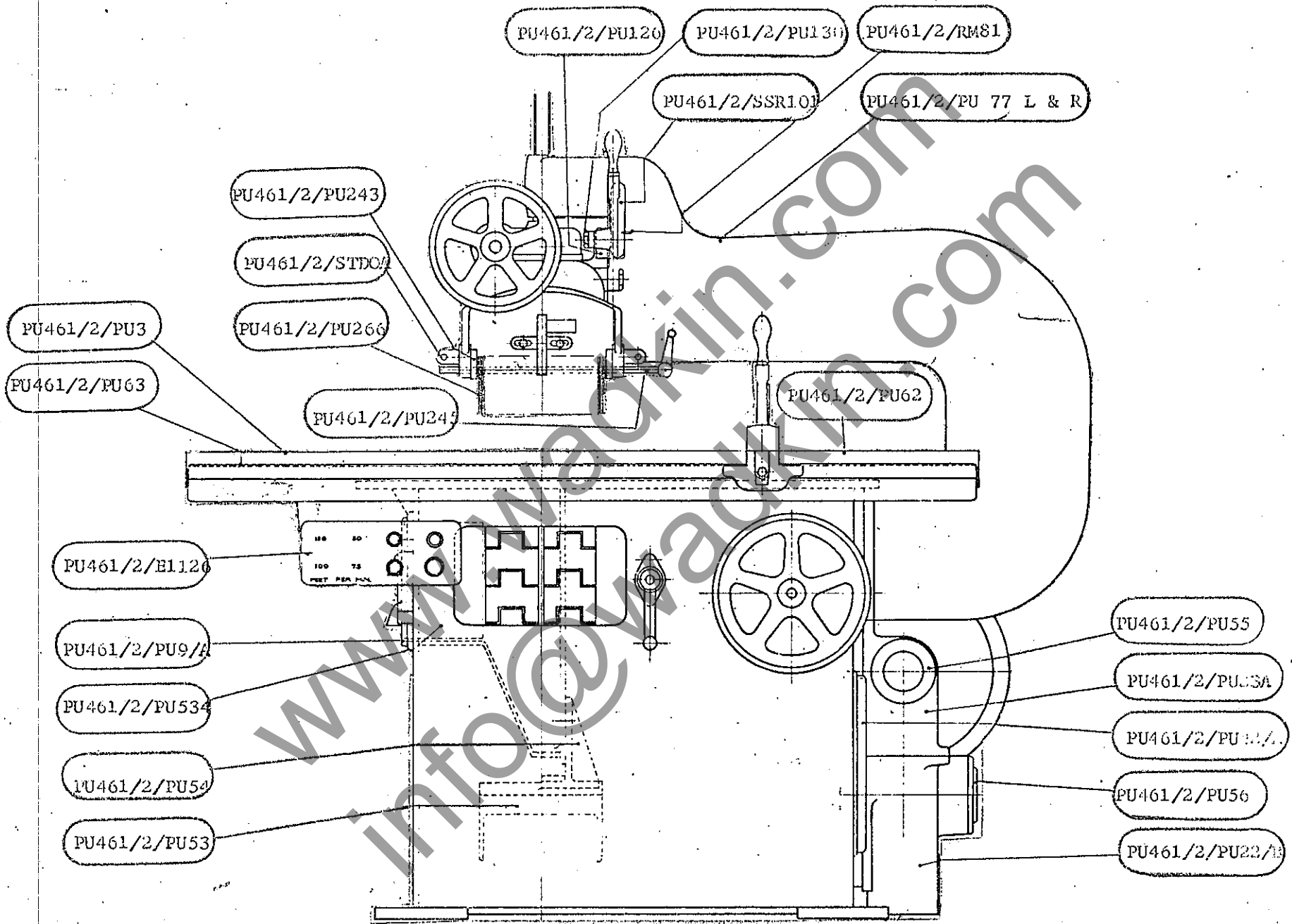

PU STRAIGHT LINE EDGER

